

PT Series Installation Manual

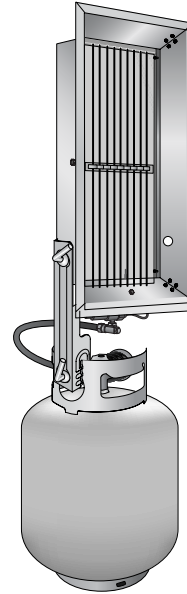

Important! This heater is designed and approved for use as a construction heater in accordance with the Standard for Gas-Fired Construction Heaters ANSI Z83.7 • CSA 2.14. CHECK WITH YOUR LOCAL FIRE SAFETY AUTHORITY IF YOU HAVE QUESTIONS ABOUT APPLICATIONS. Other standards govern the use of fuel gases and heat producing products in specific applications. Your local authority can advise you about these.



⚠ WARNING



Failure to comply with the precautions and instructions provided with this heater can result in death, serious bodily injury, and property loss or damage from hazards of fire, explosion, burns, asphyxiation, carbon monoxide poisoning, and/or electrical shock.



Only persons who can understand and follow the instructions should use or service this heater. If you need assistance or heater information such as an instruction manual, label, etc. contact the manufacturer.



Fire, burn, inhalation, and explosion hazard. Keep combustibles such as building materials, paper, or cardboard a safe distance away from the heater as recommended by the instructions. Never use the heater in spaces which do or may contain volatile or airborne combustibles or products such as gasoline, solvents, paint thinner, dust particles, or unknown chemicals.



This heater is **not approved for use in any indoor residential application**. This includes, but is not limited to, attached garages, solarium, living quarters, mobile homes, campers, tents, recreational vehicles, etcetera.

For Your Safety

Propane gas is VERY FLAMMABLE! It is scented and its strong odor is readily detectable. In the event of a leak, propane will accumulate and the possibility of a fire is present. **If you smell gas:**

- Never strike a match, create a flame, or create an electric spark.
- Move the heater outside and ventilate the area thoroughly.
- Find and correct the source of the leak before attempting to light the heater. If the leak cannot be corrected, do not tamper with the heater.
- Turn the heater "OFF" and consult the manufacturer, a qualified installer, or the gas supplier.

INSTALLER: Present this manual to the end user.

Keep these instructions in a clean and dry place for future reference.

Model#: _____ Serial #: _____
(located on rating label)

LIOPT-Rev. 29110
Print: LIOPT-1M-10/21_r1-03/22 (CDS)
Replaces: LIOPT-3M-02/21 (CDS)

Contents

1.0 Safety	3
Warning Symbols	3
Applications	3
Clearances to Combustibles	4
Safety Labels and Their Locations	5
2.0 Installation	6
Installation	6
Heater Dimensions	7
Mounting the Heater	8
3.0 Operation	9
4.0 Maintenance	10
5.0 Parts	11
6.0 Repair	12
7.0 Limited Warranty	12

WARNING

California Proposition 65

This product can expose you to chemicals including lead and carbon monoxide, which are known to the State of California to cause birth defects or other reproductive harm.

For more information, go to www.P65Warnings.ca.gov.

WARNING

Air Quality Hazard

- Do not use this heater for heating human living quarters.
- Use of direct-fired heaters in the construction environment can result in exposure to levels of CO, CO₂, and NO₂ considered to be hazardous and potentially life-threatening.
- Do not use in unventilated areas.
- Know the signs of CO and CO₂ poisoning: Headaches, stinging eyes, dizziness, disorientation, difficulty breathing, feelings of being suffocated.
- Proper ventilation air exchange (OSHA 29 CFR 1926.57) to support combustion and maintain acceptable air quality shall be provided in accordance with OSHA 29 CFR Part 1926.154, ANSI A10.10 Safety Requirements for Temporary and Portable Space Heating Devices and Equipment used in the Construction Industry or the Natural Gas and Propane Installation Codes CSA B149.1.
- Periodically monitor levels of CO, CO₂, and NO₂ existing at the construction site—at a minimum at the start of the shift and after 4 hours.
- Provide ventilation air exchange, either natural or mechanical, as required to maintain acceptable indoor air quality.
 - USA 8-Hr Time Weighted Average (OSHA 29 CFR 1926.55 App A)
 - CO 50 ppm
 - CO₂ 5000 ppm
 - USA Ceiling Limit (Short Term Exposure Limit = 15 Minutes)
 - NO₂ 5 ppm
- Ensure that the flow of combustion and ventilation air exchange cannot become obstructed.
- As the building “tightens up” during the construction phases ventilation may need to be increased.

1.0 Safety

⚠ WARNING



Improper installation, adjustment, alteration, service, or maintenance can cause property damage, injury, or death. All persons involved with the operation and maintenance of this heater must read and understand the information in this manual before use or service of the heater.

Warning Symbols

Safety is the most important consideration during installation, operation, and maintenance of the infrared heater. You will see the following symbols and signal words when there is a hazard related to safety or property damage.

⚠ WARNING

Warning indicates a potentially hazardous situation which, if not avoided, could result in death or injury.

⚠ CAUTION

Caution indicates a potentially hazardous situation which, if not avoided, could result in minor or moderate injury.

NOTICE

Notice indicates a potentially hazardous situation which, if not avoided, could result in property damage.

⚠ WARNING



Not For Indoor Residential Use. Operating an infrared heater system in residential indoor spaces may result in property damage, serious injury, or death. Use this heater in open, well ventilated space only.

Applications

This is not an explosion proof heater. Consult your local fire marshal, insurance carrier, and other authorities for approval of location and use of the heater.

Construction

The primary use of construction heaters is to provide **temporary** heating of buildings under construction, alteration, or repair. It may also be used to provide **temporary** emergency heat. This heater is **not** to be used in the home, mobile homes, campers, tents, recreational vehicles, etcetera.

For maximum safety, the building must be evaluated for potential hazards before locating and using the heater. A critical safety factor to consider before installation is the clearances to combustibles (see page 4). This appliance can be used at elevations up to 6,000 ft. above sea level without modification.

Clearances to Combustibles

⚠ WARNING



Improperly connected gas line may result in serious injury or death, explosion, poisonous fumes, toxic gases, or asphyxiation. Connect gas lines in accordance to national, state, provincial, and local codes.



Placement of explosive objects, flammable objects, liquids, and vapors close to the heater may result in explosion, fire, property damage, serious injury, or death. Do not store or use explosive objects, liquids, or vapors in the vicinity the heater.



Failure to comply with the published clearances to combustibles could result in personal injury, death, and/or property damage.



Fire, burn, inhalation, and explosion hazard. Do not place over combustible materials such as building materials, wood, paper or cardboard, or materials subject to disintegration due to expansion, such as concrete.

When deciding on a location for the heater, the minimum clearances to combustibles **must** be maintained. These distances are shown in Chart 1.1. If you are unsure of the potential hazards, consult your local fire marshal, insurance carrier, or other qualified authorities on the application of gas fired infrared heaters for approval of the proposed location.

Hazards:

For maximum safety the building must be evaluated for hazards before locating the heater system. Examples include, but not limited to:

- Gas and electrical lines
- Combustible and explosive materials
- Chemical storage areas
- Areas of high chemical fume concentrations
- Provisions for accessibility to the heater
- Combustion and ventilating air supply
- Vehicle parking areas
- Dirty, contaminated environment

A critical safety factor to consider before placement is the clearances to combustibles. **Clearance to combustibles** is defined as *the minimum distance you must have between the infrared surface, or reflector, and the combustible item*. Considerations must also be made for moving objects around the infrared heater. The following is a partial list of items to maintain clearances from:

Combustible items:

- Wood
- Paper
- Fabric
- Chemicals
- Wall or roof insulation
- Rags or towels
- Plastics

Moving Objects:

- Overhead doors
- Vehicle lifts
- Cranes
- Hoists
- Car wash equipment

IMPORTANT! Locate the unit at least 10 feet away from canvas, tarpaulins or similar coverings and secure such coverings to prevent ignition and interference with the heater. It is the responsibility of the installer to ensure that building materials with a low heat tolerance, which may degrade at a lower temperature, are protected to prevent degradation.

Chart 1.1 • Clearances to Combustibles (in Inches)

Model No.	Sides	Back	Top	Front
P-16T	18	18	48	48
P-32T	24	18	48	72

Figure 1.1 • Clearances to Combustibles

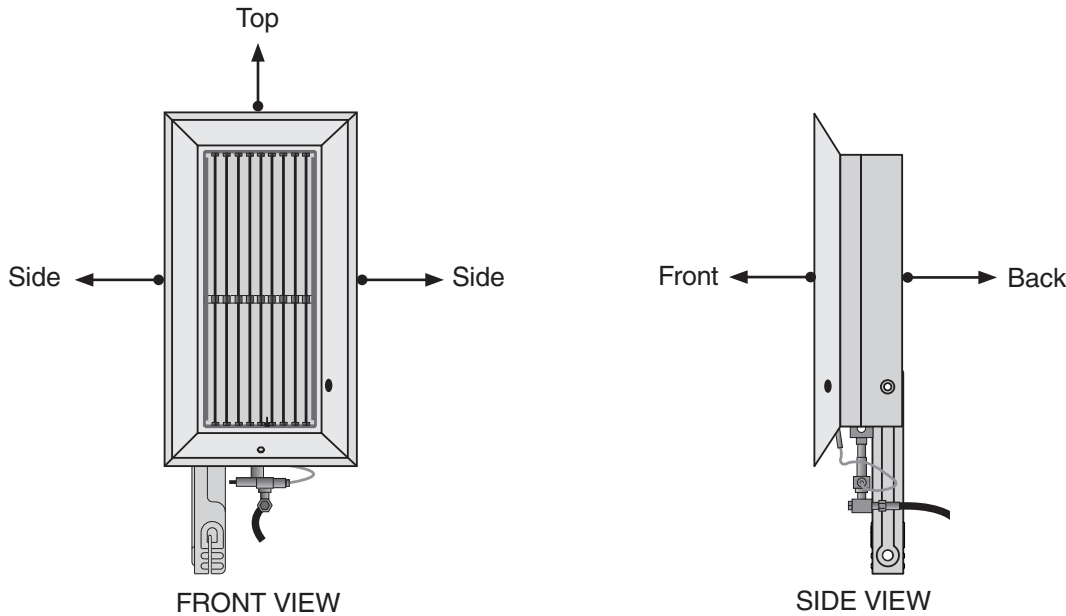

Safety Labels and Their Locations

Safety warning labels must be maintained on the infrared heater. Illustrations of the safety labels and their locations are pictured below.

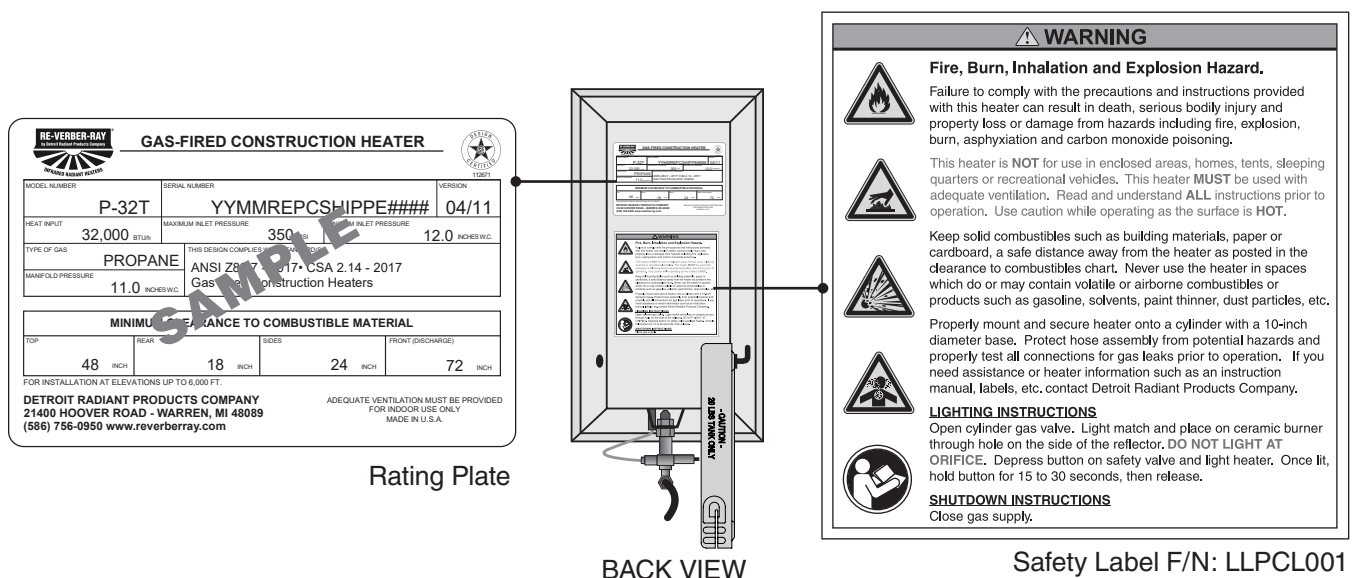

2.0 Installation

⚠ WARNING



Insufficient ventilation may result in fire, explosion, health problems, carbon monoxide poisoning, serious injury, or death. Vent enclosed spaces and buildings according to national, state, provincial, and local codes.



Overfilled propane gas cylinders may cause explosion, fire, property damage, serious injury, or death. Indications of an overfilled propane gas cylinder include failure to light and/or pressure buildup on the regulator. Return overfilled tank to the supplier and inspect the hose and regulator for damage.



Using any heater component (e.g., manifold, gas valve, gas line connector) for support may result in the heater tipping over and causing injury, fire, or explosion. Always locate the heater on a stable, secure, and level surface.

Installation

Prior to installation, verify the heater's gas type as listed on the rating plate. Installation of this heater must conform with local codes or, in the absence of local codes, with the Standard for the Storage and Handling of Liquefied Petroleum Gases, ANSI/NFPA 58 and the Natural Gas and Propane Installation Code, CSA B149.1.

Propane gas models are approved for use with a DOT 20 lb. propane gas cylinder with a 10 inch diameter base (**NOTE:** only use a vapor withdraw type cylinder. **Do not** use a forklift truck or liquid dispensing cylinder). See Chart 2.2 Operating Values for pressure specifications.

Along with maintaining the clearances to combustibles, the heater **must** be used in a well ventilated area. When the heater is temporarily used in an enclosed area, a positive air displacement of at least 4.0 CFM per 1,000 BTU/h of the heater's rated input **must be provided**.

Locate the heater on a stable, level surface and at least 10 feet away from canvas, tarpaulins, or similar coverings and secure such coverings to prevent ignition and interference with the heater. The heater must be at least 6 ft. from other propane gas containers and have at least 20 ft. between containers in the direction of the projected heat.

The use of the heater in drafty conditions may result in the loss of heater efficiency. In drafty conditions turn the heater so it faces away from the direction of the draft/wind. The heater must be placed or installed such that it is not directly exposed to water spray, rain, and/or dripping water.

The heater contained in this carton has been factory assembled and is in an operable condition without the need for adjustment or further assembly. Only use the pressure regulator (and hose, propane only) supplied with the heater. Alteration of the heater or replacement of components not specified by Detroit Radiant Products Co. voids all approvals and warranties.

Figure 2.1 • Heater Dimensions

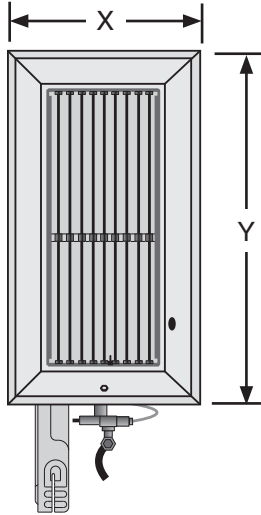

Chart 2.1 • Heater Dimensions (in Inches)

Model No.	Dim "X"	Dim "Y"
P-16T	10 1/16	13 1/8
P-32T	10 1/16	18 5/8

Chart 2.2 • Operating Values

Model No.	BTU/h	Gas Type	Manifold Pressure	Minimum Inlet Pressure (W.C.P.) *	Maximum Inlet Pressure (PSI)
P-16T	16,000	LP	11 Inches W.C.	12 Inches W.C.	350
P-32T	32,000	LP	11 Inches W.C.	12 Inches W.C.	350

* For purpose of adjustment

⚠ WARNING



Improperly connected gas lines may result in fire, explosion, poisonous fumes, toxic gases, asphyxiation, and death. Connect gas lines in accordance to national, state, and local codes.

Mounting the Heater (P-16T, P-32T)

- ❶ Attach the mounting bracket to the heater by lining up the upper hole of the bracket with the mounting hole located on the side of the heater. Fasten the two parts with the 3/8-16 thumbscrew provided.
- ❷ Connect and hand tighten the included pressure regulator to the propane gas cylinder. Turn the nut (clockwise) until it stops. Do not use a wrench or over tighten. Use only the hose and regulator assembly supplied with the heater.
- ❸ Attach the mounting bracket to the flange of the cylinder and tighten the 3/8-16 thumbscrew until the mounting bracket is rigid.
- ❹ Connect hose to the gas valve assembly. Tighten clockwise with opposing wrenches to prevent damage to the gas valve assembly. Check all gas connections for leaks using a soap and water solution. **Do not use an open flame.**

Figure 2.2 • Mounting: Propane Gas Unit

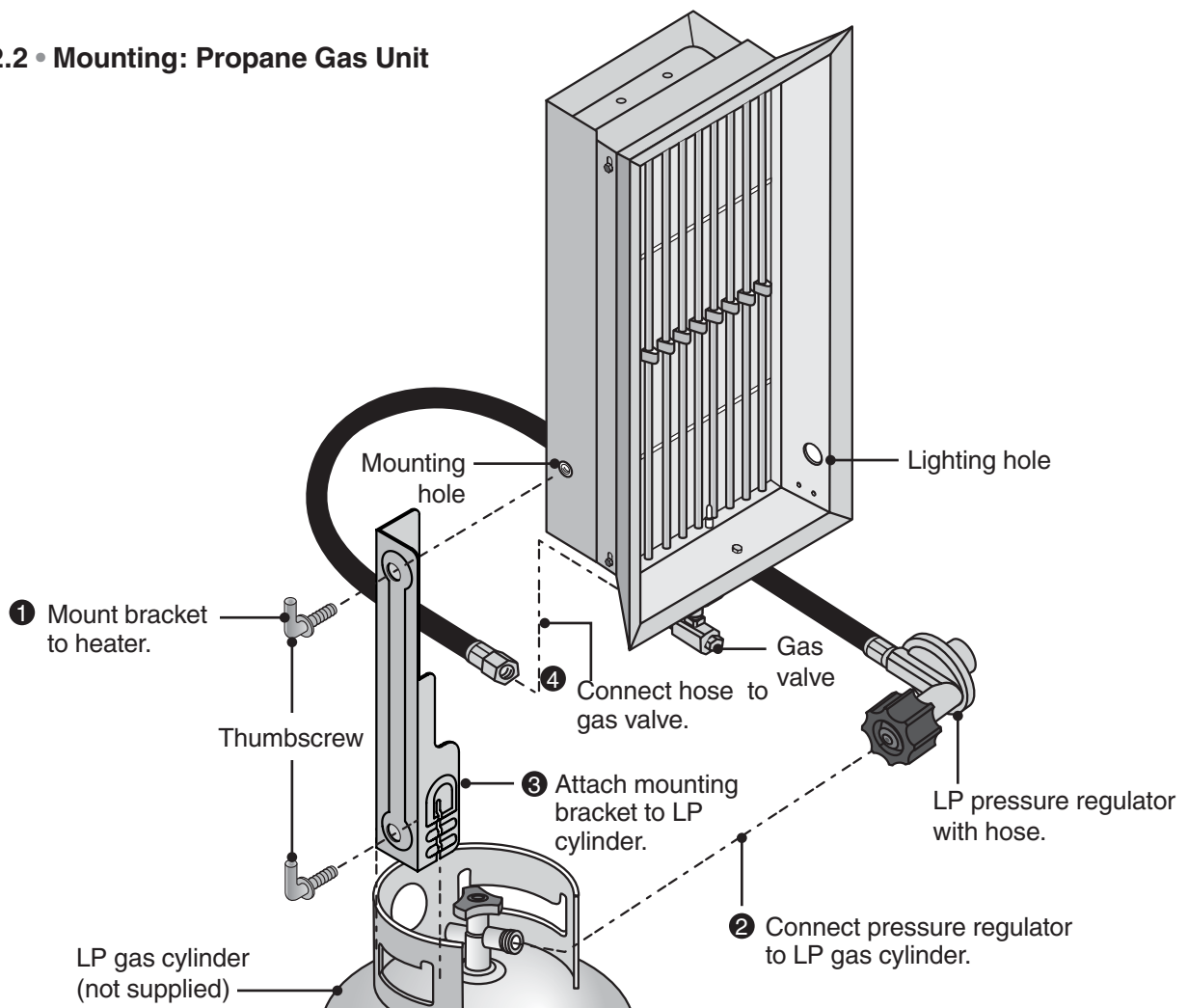

3.0 Operation

⚠ WARNING



Improperly connected or damaged gas line may result in fire, explosion, poisonous fumes, toxic gases, asphyxiation, serious injury, or death. Check the hose assembly and gas connection before each use. Gas lines must be installed in accordance to national, state, provincial, and local codes.



Ignition flame may flash during lighting of the heater which may cause burns. Stand to the side of the heater, away from the burner during ignition.

The outside surfaces of the heater are hot during operation and after use. If contact is made permanent skin damage may occur. Do not move, handle, or service the unit during operation or while hot.

Lighting the Heater:

IMPORTANT! Inspect the heater before each use (refer to section 4.0 Maintenance). Operate on a stable, level surface. Do not knock or tip the heater over while in operation.

- ❶ Open propane gas cylinder (counterclockwise). Figure 3.1.
- ❷ Check all gas connections for leaks using a soap and water solution. **Do not use an open flame to check the connection.**
- ❸ Light and place a match on the ceramic burner through the hole provided on side of reflector. **Do not light the heater at the orifice or attempt to light with a spark lighter.** Figure 3.2.
- ❹ Depress the brass button on the heater's safety gas valve and continue to hold during ignition sequence. The heater should light within 10 seconds. Figure 3.3.

NOTE: If the heater does not light within 10 seconds, wait 5 minutes before attempting to re-light.

- ❺ If lit, continue to depress the brass button for approximately 30 seconds and then release.
- ❻ If the heater flame extinguishes, wait five minutes and repeat steps 1 through 5.

Shutdown:

- ❼ Close propane gas cylinder (clockwise). Figure 3.4.

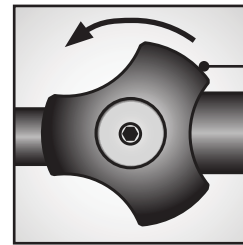

Figure 3.1

Turn handle, open gas valve.

❶ ❷

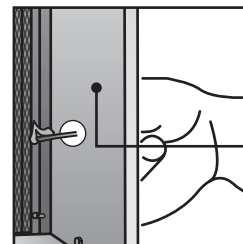

Figure 3.2

Light match, insert through hole that is located on the lower side of the reflector.

❸

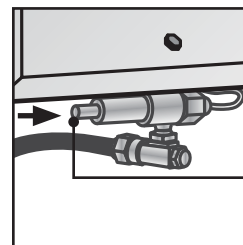

Figure 3.3

Depress button, ignite heater.

❹ ❺

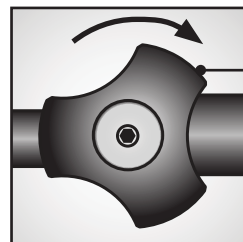

Figure 3.4

Turn handle, close gas valve.

❼

4.0 Maintenance

⚠ WARNING



Gas hoses that are cut or have abrasions and/or wear may fail and release gas resulting in fire, explosion, serious injury, or death. Replace worn or damaged hoses before use.

Never operate the heater if repairs are necessary. If the heater has not been in service for an extended period of time, the following maintenance procedures should be performed **before** heater operation:

- ❶ Inspect unit before each use and at least annually by a qualified service person.
- ❷ Using an air hose from 3-5ft. away, gently blow off any dust or dirt that has accumulated on the heater ceramics (**do not exceed 30 psi**, vacuuming is acceptable) and venturi tube.
NOTE: If the venturi tube still appears dirty, remove the orifice bracket and clean it with a brush.
- ❸ Clean orifice spud using a soft circular object (toothpick, pipe cleaner).
- ❹ Wipe the reflector clean using a soap and water solution or a non-abrasive aluminum cleaner.

Storage

Store propane gas cylinder in accordance with Chapter 5 of the Standard for the Storage and Handling of Liquefied Petroleum Gases, ANSI/NFPA 58 and all applicable codes. If the heater is not to be used for an extended period of time, store it in the original carton or a sealed polyethylene bag. When storing the heater indoors, disconnect the propane gas supply cylinder and remove the cylinder from the heater.

Chart 4.1 • Troubleshooting Guide

Symptom	Possible Cause	Corrective Action
Heater fails to light.	<ul style="list-style-type: none"> • Cylinder gas valve closed. • Cylinder overfilled. • Excessive draft. • Inadequate gas pressure. • Heater safety gas valve defective. • Obstruction in orifice spud. 	<ul style="list-style-type: none"> • Open valve. • See safety warning, page 6. • Relocate or reposition heater. • Check gas pressure. See Chart 2.2. • Replace faulty valve. • Clean or replace orifice.
Heater lights - flame extinguishes when releasing the brass button on the safety gas valve (NOTE: after depressing the button for one minute).	<ul style="list-style-type: none"> • Inadequate gas pressure. • Insufficient fuel supply. • Thermocouple defective or loose. • Heater safety gas valve defective. 	<ul style="list-style-type: none"> • Check gas pressure. See Chart 2.2. • Provide adequate fuel supply. • Replace or tighten connection into valve. • Replace faulty valve.
Fuel mixture burning within rayhead assembly.	<ul style="list-style-type: none"> • Gas connection loose. • Inlet pressure too high. • Cracked or broken ceramic. • Improperly lighting. 	<ul style="list-style-type: none"> • Tighten and check for leaks. • Reduce to proper range. See Chart 2.2. • Replace rayhead assembly. • Light at ceramic burner element, not at the orifice (see Section 3.0).
Ceramic temperature is below 1700° F (NOTE: no orange glow during operation).	<ul style="list-style-type: none"> • Orifice spud misaligned. • Obstruction in orifice spud. • Inadequate gas pressure. • Cylinder gas valve not fully open. • Kinked or obstructed gas supply line. 	<ul style="list-style-type: none"> • Replace orifice bracket. • Clean or replace. • Check gas pressure, See Chart 2.2. • Open cylinder gas valve completely. • Straighten or clean.

5.0 Parts

Figure 5.1 • Components

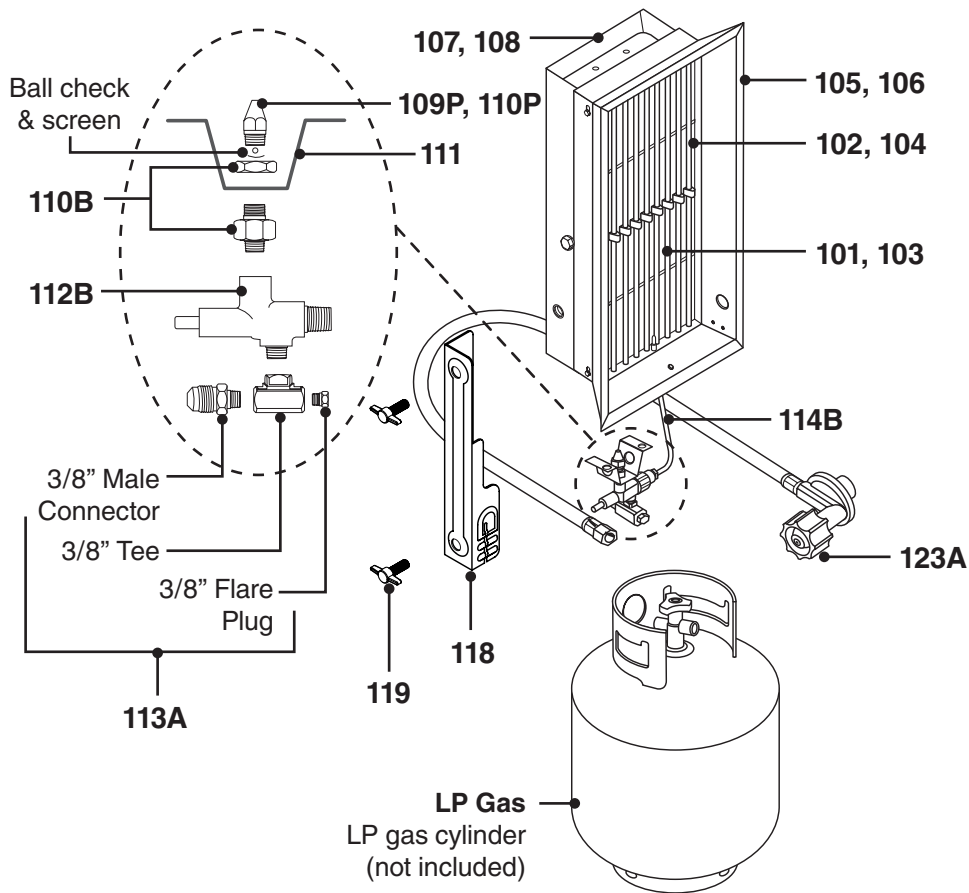

PART#	DESCRIPTION	PART#	DESCRIPTION
P-101	Rayhead assembly for P-16T (Less Rods)	P-110B	Orifice fittings
P-102	Rods for P-16T (Qty. 9)	P-111	Heater orifice spud mounting bracket
P-103	Rayhead assembly for P-32T (Less Rods)	P-112B	Brass button manual safety gas valve - 1/8" MPT X 1/8" FPT (mates w/ P-113A)
P-104	Rods for P-32T (Qty. 9)	P-113A	90° flared tube fitting - 3/8" O.D. X 1/8" FPT X 1/8" NPT
P-105	Reflector assembly for P-16T	P-114B	Thermocouple w/ mounting clip for P-112B
P-106	Reflector assembly for P-32T	P-118	Cylinder mounting bracket
P-107	Outer heater casing for P-16T	P-119	Thumb screw with shoulder 3/8-16 (Qty. 2)
P-108	Outer heater casing for P-32T	P-123A	24" hose and regulator assembly w/ Type-1 inlet
P-109P	Propane orifice spud for P-16T	P-125	LP gas valve, assembled w/ all fittings for P-32T
P-110P	Propane orifice spud for P-32T	P-126	LP gas valve, assembled w/ all fittings for P-16T

Visit <http://store.reverberray.com> for additional replacement parts information.

6.0 Repair

This heater is covered by a limited warranty (see Section 7.0 Limited Warranty). Detroit Radiant Products also offers repair services for the following condition:

Symptom: No orange glow on ceramic surface (and/or abnormal noise) during operating.

Possible Cause: Cracked ceramics, loose ceramics, missing gasket material, or other physical abuses resulting in the fuel mixture burning within the rayhead assembly (behind ceramic surface).

Immediate Action: Turn the off heater.

Corrective Action: Replace the rayhead assembly or return it to Detroit Radiant Products for repair.

Repair cost is \$55.00 for each P-16T model and \$70.00 for each P-32T model. Repair charges include return shipping and handling costs. Units can be returned COD via UPS (additional fees for COD service will apply). Include a packing list with an explanation of the heater's symptoms.

The preferred method of payment is credit card (Visa, MasterCard, or Discover). Include a phone number on the packing list of a contact who can provide valid credit card information. The alternate payment method is personal check. Please make check payable to Detroit Radiant Products Company for the repair cost amount above.

DO NOT include the mounting accessories (tank, hose, bracket, regulator, etc.). Be sure to enclose the heater (packaged tightly), payment information (a check or phone number to contact for payment), the return address, and a contact phone number. If your heater requires work in addition to burner reconstruction, you will be contacted with a quote. Lead-time is 2-5 working days. Heater returns should be addressed to:

Repair Department
c/o Detroit Radiant Products Co.
21400 Hoover Rd.
Warren, MI 48089

Please call 800-222-1100 with questions.

7.0 Limited Warranty

Heater models P-16T and P-32T are warranted by Detroit Radiant Products Co. to the original user against defects in workmanship or materials under use for 90 days after date of purchase. The company's sole obligation under this warranty is limited to furnishing replacement parts, FOB Warren, Michigan for any parts which the company's examination discloses to its satisfaction to be defective. Defective parts are to be returned to the company, transportation charges prepaid. The company's liability for consequential and incidental damages is expressly disclaimed.



© 2022 Detroit Radiant Products Co.
21400 Hoover Road • Warren, MI 48089
Phone: (586) 756-0950 Fax: (586) 756-2626
www.detroitradiant.com • sales@drp-co.com

