

AVS2 Series

Installation Manual

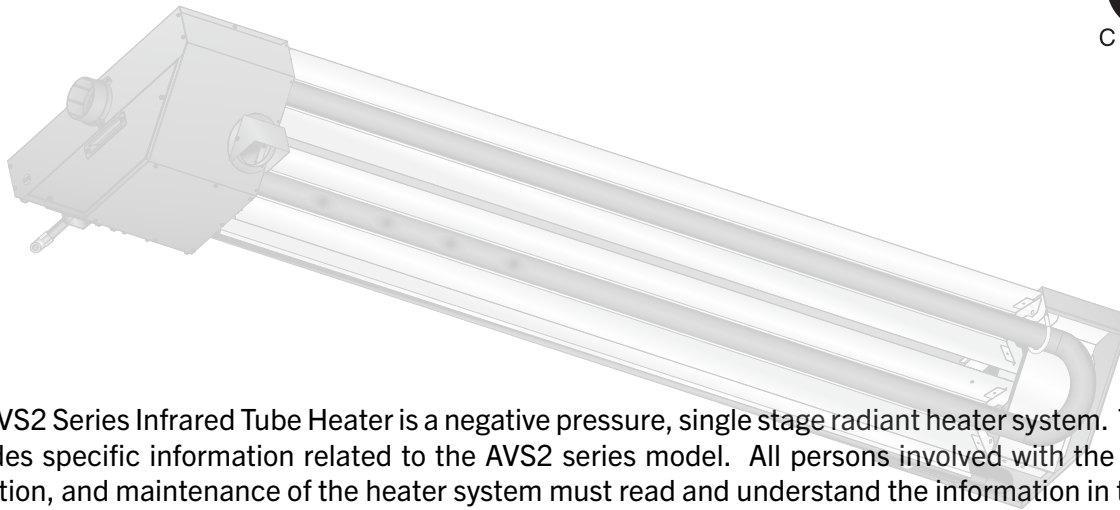

The AVS2 Series Infrared Tube Heater is a negative pressure, single stage radiant heater system. This manual provides specific information related to the AVS2 series model. All persons involved with the installation, operation, and maintenance of the heater system must read and understand the information in this manual.

⚠ WARNING



Improper installation, adjustment, alteration, service, or maintenance can cause property damage, injury, or death. Read the installation, operation, and maintenance instructions thoroughly before installing or servicing this equipment.

This heater **must** be installed and serviced by trained gas installation and service personnel only. Failure to comply could result in personal injury, asphyxiation, death, fire, or property damage.



Do not store or use gasoline or other flammable vapors and liquids in the vicinity of this or any other appliance.

In locations used for the storage of combustible materials, signs **must** be posted to specify the maximum permissible stacking height to maintain the required clearances from the heater to the combustibles. Signs must either be posted adjacent to the heater thermostats or, in the absence of such thermostats, in a conspicuous location.



Not for residential use! Do not use this heater in the home, sleeping quarters, attached garages, etc. Installation of a commercial tube heater system in residential indoor spaces may result in property damage, serious injury, asphyxiation, or death.

For Your Safety

If you smell gas:

- Open windows.
- Do not touch any electrical switch.
- Extinguish any open flame.
- Do not use any phone in your building.
- Do not try to light any appliance.
- Immediately call your gas supplier from a neighbor's phone.
- Follow the gas supplier's instructions.
- If you cannot reach your gas supplier, call the fire department.

INSTALLER: Present this manual to the end user.

Keep these instructions in a clean and dry place for future reference.

Model#: _____ Serial #: _____
(located on rating label)

LIOAVS2 - Rev. 12416

Print: 2M-01/23 (CDS)

Replaces: LIOAVS2-5M-01/20 (CDS)

Contents

1.0 Introduction	3
Overview	3
Heater Components	3
Specifications	3
Safety Labels and Their Locations	4
2.0 Safety	6
Warning Symbols	6
Applications	6
Standards, Certifications, and Government Regulations	7
Clearances to Combustibles	7
3.0 Installation	10
Design Considerations and Prechecks	10
Heater Packaging	12
Hanging the Heater	12
Heater Assembly	13
Installing the Reflector Assembly	14
Preparing Points for Hanging	15
Hanging the Pre-Assembled Unit	16
Venting	18
Vertical Venting (Category I)	20
Horizontal Venting (Category III)	22
Common Venting (Category I)	24
Unvented Operation	25
Combustion Air Requirements	26
Gas Supply	28
Electrical Requirements and Wiring Diagrams	33
Thermostat Connection	34
4.0 Operation	36
Start-up and Shutdown Procedure	36
Sequence of Operation	37
5.0 Maintenance	38
Troubleshooting Guide	38
Heater Components and Parts List	42
Routine Inspection	44
Limited Warranty Terms and Conditions	47
Kit Contents Check List	48

1.0 Introduction

Overview

The intent of this manual is to provide information regarding general safety, installation, operation, and maintenance of this radiant tube heater. You must read and understand all instructions and safety warnings before installing or servicing the radiant tube heater. This manual is the property of the owner and must stay with the owner or unit after installation is complete.

Heater Components

Prior to installation, verify that the heater’s gas type and voltage (as listed on the rating plate) match that of your application. Also, verify that you have received all heater components included with your radiant tube heater. Refer to page 48 for a list of the kit contents for your series heater. Materials not included in the heater kit contents (e.g., screws, vent material, terminals, etc.) are the responsibility of the installer. Notify your product representative or Detroit Radiant Products of any discrepancy or missing kit contents prior to installing the heater.

Specifications

Chart 1.1 • AVS2 Series Specifications

Model Number	Gas Type	BTU/h Input	Recommended Mounting Heights*	Unit Weight	Overall Unit Length
AVS2-60N	Natural Gas	60,000	6 to 8 ft.	140 lbs.	112"
AVS2-60P	Propane	60,000	6 to 8 ft.	140 lbs.	112"
AVS2-80N	Natural Gas	80,000	6 to 9 ft.	140 lbs.	112"
AVS2-80P	Propane	80,000	6 to 9 ft.	140 lbs.	112"

* Recommended mounting heights are provided as a guideline. Actual conditions may dictate variations from this data.

Chart 1.2 • Shipping Dimensions

AV Series	Length		Width		Height		Weight	
	in	mm	in	mm	in	mm	lbs	Kg
Burner Box	31.50	800	17.50	445	15.50	394	45	21
Tube Box	98.50	2,502	29.25	743	13.00	330	95	43

NOTE: See Kit Contents on page 48.

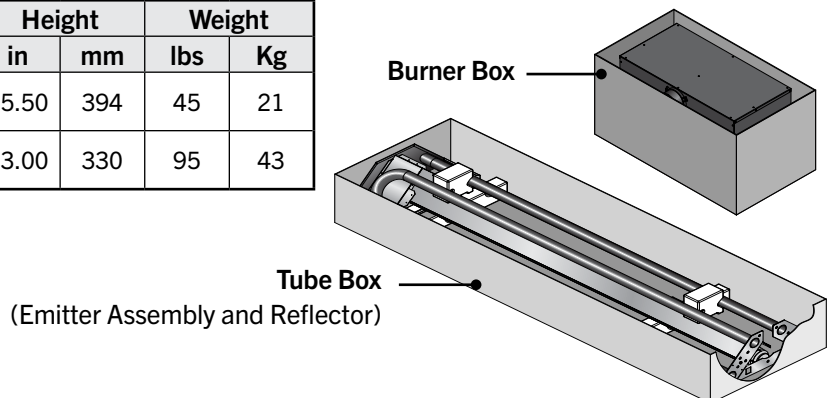

⚠ WARNING



Improper installation, adjustment, alteration, service, or maintenance can cause property damage, serious injury, or death. Read and understand the installation, operating, and maintenance instruction thoroughly before installing or servicing this equipment. Only trained, qualified gas installation and service personnel may install or service this equipment.

Safety Labels and Their Locations

All labels must be maintained on the radiant tube heater and should be replaced if they become illegible. Contact either your local distributor or the product manufacturer for obtaining replacement signs or labels.

It is important to provide warnings to alert individuals to potential hazards and safety actions. In locations used for the storage of combustion materials, post a placard “specifying the maximum permissible stacking height to maintain the required clearances from the heater to the combustibles” near the heater’s thermostat or, in the absence of such thermostats, in a conspicuous location. Contact Detroit Radiant Products or an authorized dealer for Clearance Safety Limit Signs or for Clearance Safety Limit Tags (one tag is provided with each heater).

REVERBER-HAY LOW-INTENSITY INFRARED HEATER RADIATEUR À INFRAROUGE À FAIBLE INTENSITÉ	
MODEL NUMBER AVS2-80P	SERIAL NUMBER YYMMREPCSHIPPE#### 01/16
MAX. HEAT INPUT MAX. DEBIT CALORIFIQUE 80,000 BTU/H	HEATER BUILD TYPE C1
MIN. CLEARANCE MIN. DEBIT CALORIFIQUE N/A	VENT CATEGORY CATEGORIE II
TYPE OF GAS PROPANE	HEATER BURNER TYPE SINGLE
VENT CATEGORY CATEGORIE II	HEATER BURNER TYPE SINGLE
THIS DESIGN COMPLIES WITH STANDARD ANSI Z83.20B-2011 • CSA2 34B-2011 RADIANT TUBE HEATER AGA 7-89 RESIDENTIAL RADIANT TUBE HEATER	FOR AGRICULTURAL USE ONLY FOR INDOOR OR OUTDOOR USE MADE IN U.S.A.
DETROIT RADIANT PRODUCTS COMPANY 21400 HOOVER ROAD - WARREN, MI 48089 (586) 756-9950 www.reverberray.com	

Combustion Air Connector TP-114 TP-3014 For use with 4 inch vent pipe
F/N: LLAC023
Combustion Air Connector

SERVICE ACCESS PANEL
FAN, BURNER & IGNITER COMPARTMENT
1. Turn off gas & electricity.
2. Remove 1/4 inch sheet metal screws.
3. Remove cover by lifting top.
CAUTION: HOT SURFACE. REMOVE FOR SERVICE ONLY.
KEEP COVER IN PLACE. REMOVE FOR SERVICE ONLY.

F/N: LLTB035
(Located on top panel)

Rating Plate

DO NOT ROTATE CONTROL ASSEMBLY
USE TWO WRENCHES TO TIGHTEN
FOR GAS ONLY

F/N: LLTB018 (Natural Gas)
F/N: LLTB019 (Propane Gas)

WARNING
Avoid Serious Injury, Death, or Property Damage. Maintain Clearances to Combustibles to Prevent the Risk of Fire.
Clearances to combustibles must be maintained at all times in order to prevent the ignition of combustible materials. In locations used for the storage of combustible materials, signs must be posted to specify the maximum permissible stacking height to maintain the required clearances from the heater to the combustibles. Signs must either be posted adjacent to the heater's thermostat or, in the absence of such thermostats, in a conspicuous location. Clearances are provided on the heater's safety label and in the heater's Installation, Operation, and Maintenance manual. Product installation and operation must comply with applicable standards, codes, and regulations. Post this tag adjacent to the heater's thermostat or controls before operating the heater.
California Proposition 65
This product can expose you to chemicals including lead and carbon monoxide, which are known to the State of California to cause both defects or other reproductive harm.
For more information go to www.P65Warnings.com.

F/N: LL001 - Clearance Safety Tag (Affix adjacent to heater's thermostat)

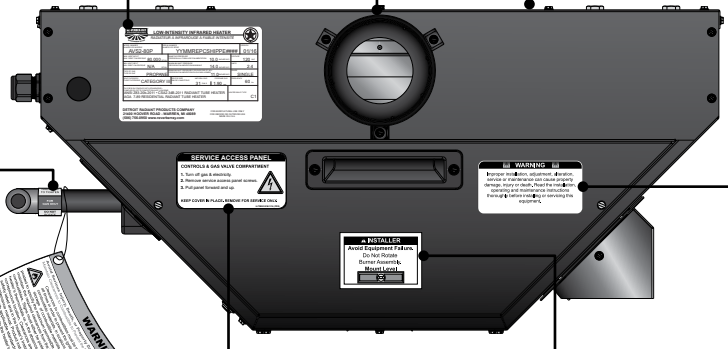

SERVICE ACCESS PANEL
CONTROLS & GAS VALVE COMPARTMENT
1. Turn off gas & electricity.
2. Remove service access panel screws.
3. Pull panel forward and up.
KEEP COVER IN PLACE. REMOVE FOR SERVICE ONLY.
F/N: LLTB052

WARNING
Improper installation, adjustment, alteration, service or maintenance can cause property damage, injury or death. Read the installation, operating and maintenance instructions thoroughly before installing or servicing this equipment.
F/N: LLTB037

INSTALLER
Avoid Equipment Failure.
Do Not Rotate Burner Assembly, Mount Level

F/N: LLTB014
Mount Level

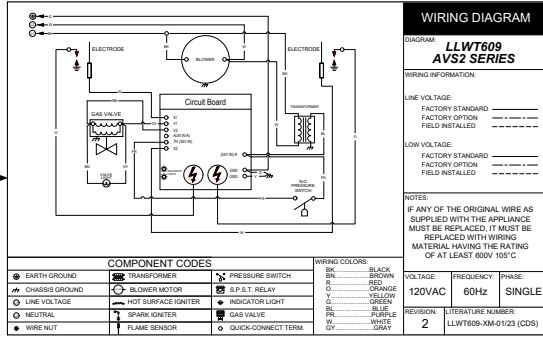

Electrical Label
(Located inside service panel)



F/N: LLLOG013
Logo Label

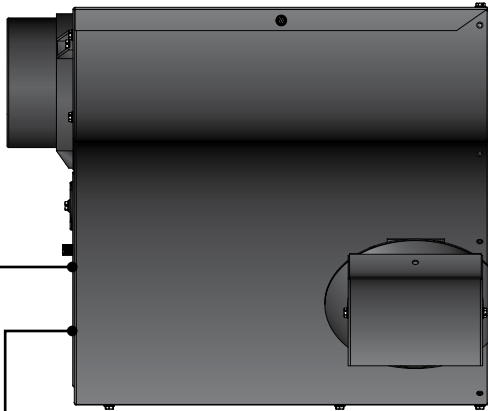

Right Panel

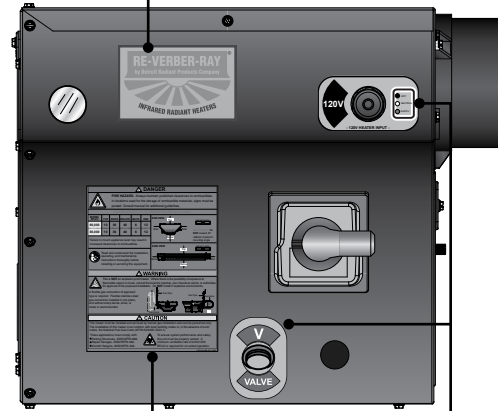

Left Panel

AVS2-80P Serial No.: 1611XXXXXXXXX 0001

Production Code: AVS2 Stock: None
 Version: 01.16 Add-On: N/A

Data on this label is for the model shown on this label. If your heater has been converted, this information is not accurate. Please contact the factory for assistance.

BURNER COMPONENTS: (Specify TP-F#)

Part	Part No.	Disc.	Term.	None	N/A
Gas Valve	Two-Stage	3140	None		
Circuit Board	Ignition Control	851B	None		
Wire Harness	3 PCS Harness	3252	None		
N.O. Switch	None	N/A	Fasco Lp.	55A	
N.O. Vt. Orifice	None	N/A	50% - 120V	55B	
N.C. Switch	None	N/A	Alt. Fan:	When Specified	
N.C. Vt. Orifice	None	N/A	Relay:	None	
Diff Switch	IS2010699	264E	Elim:	None	N/A
Diff Vt. Orifice	Grey (x / y)	24 Volt In:	None	334	
Igniter	Norton	50	120 Volt In:	120V Cord	333
Burner	High	201B	Gas In:	7/8" PC Flare	83
1/2" Tube	4" Gas	1160	Extra Vt. Orifice:	None	
Inst. Lights	Yellow - 120V	828			

HEATER Orifice Type: C1 C2 C3
 TYPE: Gas: TP-204# 3 3 1
 Air: TP-44# 1 1/2" 1 5/8" 1 5/8"

Internal Use Only:
 Electric: LLWT603 Special 1: 17
 Tag: None Special 2: 1 7/16"

For parts replacement information, contact factory at 588-756-0950 or visit www.drp-co.com/parts.

Bill of Materials
(Located inside the service panel)

⚠ DANGER

FIRE HAZARD. Always maintain published clearances to combustibles. In locations used for the storage of combustible materials, signs must be posted. Consult manual for additional guidelines.

CLEARANCES TO COMBUSTIBLES (in inches)

MODEL	TOP	SIDES	BELOW	BACK	END
60,000	10	36	40	6	12
80,000	10	36	40	6	12

Failure to mount appliance level may result in increased clearances to combustibles.

⚠ WARNING

This is NOT an explosion-proof heater. Where there is the possibility of exposure to flammable vapors or dusts, consult the local fire marshal, your insurance carrier, or authorities for approval of the proposed installation. Do NOT install in explosive environments.

A flexible gas connection of approved type is required. Flexible stainless steel gas connectors installed in one plane, and without sharp bends, kinks, or twists is recommended.

⚠ CAUTION

This heater must be installed and serviced by trained gas installation and service personnel only. The installation of this heater must conform with local building codes or, in the absence of such codes, the National Fuel Gas Code (NFPA 54/ANSI Z223.1).

These applications must comply with:

- Parking Structures, ANSI/NFPA 88A.
- Repair Garages, ANSI/NFPA 30A.
- Aircraft Hangars, ANSI/NFPA 409.

To ensure system performance and safety, this unit must be properly vented. A minimum ventilation rate of 4cfm/1000 BTU/h is required for unvented operation.

F/N: LLTCL013: Clearances to Combustibles and Gas Data Label

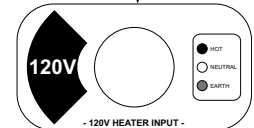

F/N: LLV3EP1

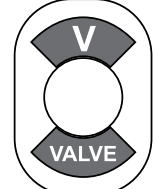

F/N: LLV2EP17

2.0 Safety

Read and understand all safety information and warnings in this manual prior to installation, operation, and maintenance of this heater. Warnings indicate a potentially hazardous situation which, if not avoided, could result in injury or death.

⚠ WARNING



Improper installation, adjustment, alteration, service, or maintenance can cause property damage, serious injury, or death. Read and understand the installation, operating, and maintenance instructions thoroughly before installing or servicing this equipment. Only trained, qualified gas installation and service personnel may install or service this equipment.

Warning Symbols

Safety is the most important consideration during installation, operation, and maintenance of the radiant tube heater. You will see the following symbols and signal words when there is a hazard related to safety and/or property damage.

⚠ WARNING

Warning indicates a potentially hazardous situation which, if not avoided, could result in serious injury or death.

⚠ CAUTION

Caution indicates a potentially hazardous situation which, if not avoided, could result in minor or moderate injury.

NOTICE

Notice indicates a potentially hazardous situation which, if not avoided, could result in property damage.

Applications

This is **not** an explosion proof heater. No radiant tube heater may be used in a Class 1 or Class 2 Explosive Environment. Consult your local fire marshal, insurance carrier, and other authorities for approval if the proposed installation is in question.

Agricultural Applications

Unless otherwise indicated, radiant tube heaters are designed and certified for use in agricultural buildings such as poultry houses, dairy parlors, and swine houses. For maximum safety, the building must be evaluated for potential problems before installing the heating system. A critical safety factor to consider before installation is the clearances to combustibles.

⚠ WARNING



Not For Residential Use. Do not use this heater in the home, sleeping quarters, attached garages, etc. Installation of a commercial tube heater system in residential indoor spaces may result in property damage, serious injury, or death.

Standards, Certifications, and Government Regulations

Installation of this radiant tube heater must conform with all applicable local, state, and national specifications, regulations, and building codes. Contact the local building inspector and/or fire marshal for guidance. In the absence of local codes, the installation must conform to the latest edition of:

United States: National Fuel Gas Code, ANSI Z223.1 (NFPA 54).

Canada: CAN/CSA B149.1, Natural Gas and Propane Installation Code

Copies of these standards can be viewed or purchased at www.nfpa.org or www.scc.ca

Clearances to Combustibles

A critical safety factor to consider before installation is the clearances to combustibles. **Clearance to combustibles** is defined as the minimum distance you must have between the tube surface, or reflector, and the combustible item. Considerations must also be made for moving objects around the radiant tube heater. The following is a partial list of items from which to maintain clearances:

Combustible/Degrading Items:

- Wood
- Paper
- Fabric
- Chemicals
- Paint
- Parked vehicles
- Gasoline
- Storage racks
- Plastics
- PVC Conduit/Pipe
- Flexible gas lines
- Fogger Lines
- Tri-Ply
- Drinker Lines
- Auger Lines
- Feed Pans/Lines

Moving Objects:

- Overhead doors
- Vehicles & vehicle lifts
- Cranes
- Hoists
- Trailers
- Catching Machine

WARNING

California Proposition 65

This product can expose you to chemicals including lead and carbon monoxide, which are known to the State of California to cause birth defects or other reproductive harm.

For more information, go to www.P65Warnings.ca.gov.

When installing the radiant heating system, the minimum clearances to combustibles for your series radiant tube heater and system configuration must be maintained. These distances are shown in Chart 2.1 on page 9 and on the burner control box. If you are unsure of the potential hazards, consult your local fire marshal, fire insurance carrier, or other qualified authorities on the installation of gas fired radiant tube heaters for approval of the proposed installation.

In locations used for the storage of combustible materials, signs must be posted to specify the maximum permissible stacking height to maintain the required clearances from the heater to the combustibles. Signs must either be posted adjacent to the heater's thermostat or in a conspicuous location.

⚠ WARNING



Placement of explosive objects, flammable objects, liquids, and vapors close to the heater may result in explosion, fire, property damage, serious injury, or death. Do not store or use explosive objects, liquids, or vapors in the vicinity the heater.

Common Hazards:

For maximum safety the building must be evaluated for hazards before installing the heating system.

Examples include, but are not limited to:

- Gas and electrical lines
- Combustible and explosive materials
- Chemical storage areas
- Areas of high chemical fume concentrations
- Provisions for accessibility to the heater
- Adequate clearances around air openings
- Combustion and ventilating air supply
- Vehicle parking areas
- Vehicles with lifts or cranes
- Storage areas with stacked materials
- Lights
- Sprinkler heads
- Overhead doors and tracks
- Dirty or contaminated environments

⚠ CAUTION

Children and adults should be alerted to the hazards of high surface temperatures and should stay away to avoid burns or clothing ignition.

Young children should be carefully supervised when they are in the same space as the heater.

Clothing or other flammable materials should not be hung from the heater, or placed on or near the heater.

Any guard or other protective device removed for servicing the heater must be replaced prior to operating the heater.

Installation and repair should be done by a qualified service person. The heater should be inspected before use and at least annually by a qualified service person. More frequent cleaning may be required as necessary. It is imperative that the control compartment, air passageways, and burner(s) of the heater be kept clean.

⚠ WARNING



Failure to comply with the stated clearances to combustibles may result in personal injury, property damage, and/or death.

Failure to mount the appliance level may result in personal injury, property damage, and/or death.

Chart 2.1 • Clearances to Combustibles in Inches (see Figure 2.1)

Model Number	Top	Sides	Below	Back	End
AVS2-60 [N, P]	10	36	40	6	12
AVS2-80 [N, P]	10	36	40	6	12

Heaters shall be mounted on a 0° angle only.

The stated clearance to combustibles represents a surface temperature of 90°F (50°C) above room temperature. Building materials with a low heat tolerance (such as plastics, PVC conduit/pipe, vinyl siding, canvas, tri-ply, etc.) may be subject to degradation at lower temperatures. It is the installer’s responsibility to ensure that adjacent materials are protected from degradation.

Figure 2.1 • Clearances to Combustibles

SIDE VIEW



END VIEW

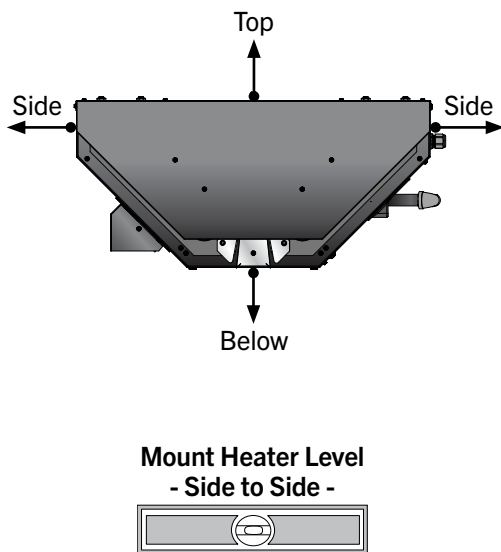

REAR VIEW Showing Pitched Roof Installation

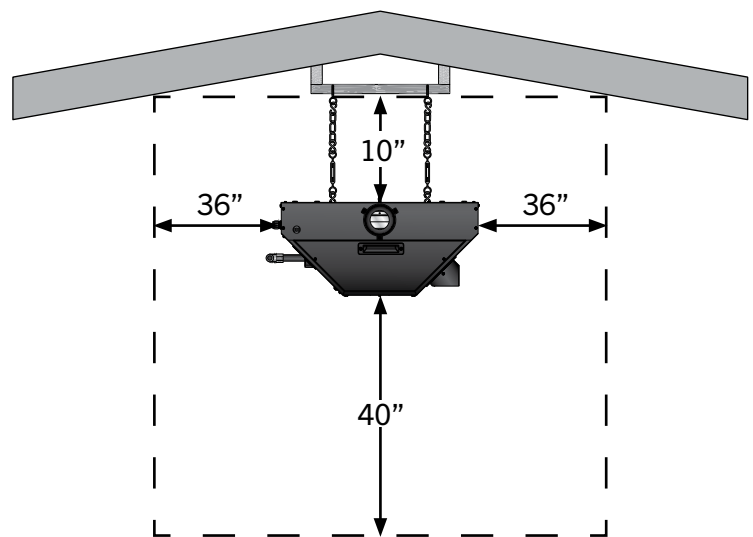

3.0 Installation

⚠ WARNING



Improper installation, adjustment, alteration, service, or maintenance can cause property damage, serious injury, or death.

Read and understand the installation, operating, and maintenance instructions thoroughly before installing or servicing this equipment.

Only trained, qualified gas installation and service personnel may install or service this equipment.

Design Considerations and Prechecks

Placement of infrared heaters is influenced by many factors. Aside from safety factors, considerations such as the number of heater or vent elbows that are allowed, maximum vent lengths, ducting of combustion air, and combining exhaust vents are a few examples. All installation manuals along with national, state, provincial, and local codes address these issues. It is critical that you read, understand, and follow all guidelines and instructions.

To ensure a properly designed heating system, a layout should be developed for the correct placement of the heating appliance, vents, and combustion air intake ducts. Inspect and evaluate the mounting conditions, vent locations, gas supply, and wiring. Refer to Chart 3.1 on page 11 for the recommended mounting heights and coverages for the model being installed.

The effective infrared surface temperature of a person or object may be diminished with wind above 5 mph. The use of adequate wind barrier(s) may be required.

NOTE: When heated, materials high in hydrocarbons (solvents, paint thinner, mineral spirits, formaldehydes, etc.) can evaporate. This may result in odors or fumes being emitted into the environment. To correct this problem, clean the area and/or introduce additional ventilation. Heaters installed and serviced in accordance with the installation manual do not emit odors into the environment.

IMPORTANT: Fire sprinkler heads must be located at an appropriate distance from the heater. This distance may exceed the published clearance to combustibles as posted on the heater. Certain applications may require the use of high temperature sprinkler heads or relocation of the heaters.

⚠ CAUTION

Sprinkler systems containing propylene glycol or other flammable substances are not to be used in conjunction with this heater without careful consideration for, and avoidance of, potential fire or explosion hazards. For further information consult NFPA 13.

Chart 3.1 • Recommended Mounting Heights and Coverages*

Model No.	Input BTU/h	Recommended Mounting Height (ft.)	Approximate Coverage Area (LxW)
AVS2-60 [N,P]	60,000	6 to 8	24 x 28
AVS2-80 [N,P]	80,000	6 to 9	26 x 32

NOTE: This chart is provided as a guideline. Actual conditions may dictate variation from this data.

*Factory recommended mounting heights and approximate coverages are listed as a guideline for designing for total building heat. However, certain applications such as spot heating, freeze protection and outdoor heating generally require additional heat per square foot to comfortably heat these areas. Clearances to Combustibles must always be maintained (Chart 2.1; Page 9).

Figure 3.1 • Application Guidelines

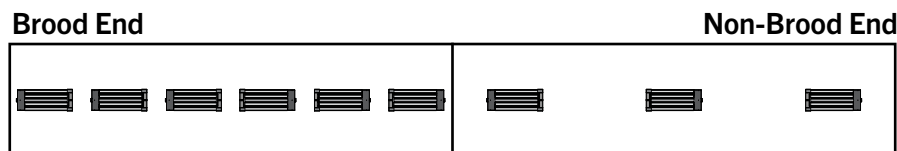

For houses 400 feet long by 40 to 50 feet wide

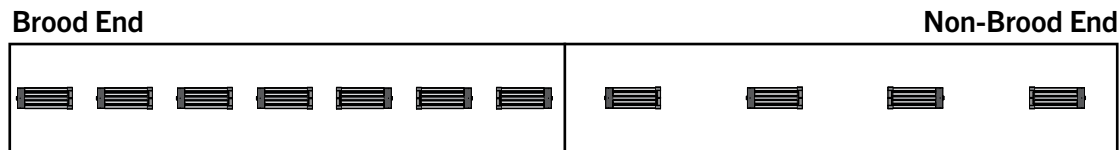

For houses 500 feet long by 40 to 50 feet wide

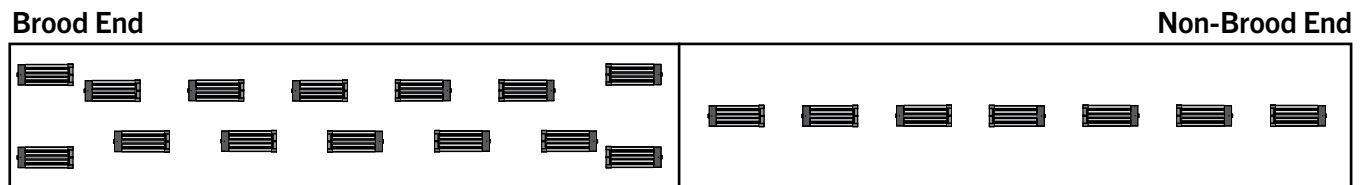

For houses 600 feet long by 50 to 66 feet wide

Chart 3.2 • Heater Spacing**

House Length	House Width		Approx. Distance from End Wall and from Curtain	Approx. Distance Between Heaters
400 Feet	40 to 50 Feet	Brood End	10-20 Feet	31-37 Feet
		Non-Brood End	35-45 Feet	57-63 Feet
500 Feet	40 to 50 Feet	Brood End	10-20 Feet	34-40 Feet
		Non-Brood End	30-40 Feet	57-63 Feet
600 Feet	50 to 66 Feet	Brood End	10-20 Feet	46-52 Feet
		Non-Brood End	25-35 Feet	37-43 Feet

** Layouts may vary depending on house style, size and climate. Chart 3.2 is based on 80,000 BTU/h.

Heater Packaging

Heaters are made up of three pieces shipped in two boxes; the burner control box in the first box and the emitter assembly and reflectors in the second box (see Figure 3.2).

Figure 3.2 • Heater Packaging • 2 Pieces

NOTE: Included Air Intake Kit not pictured.

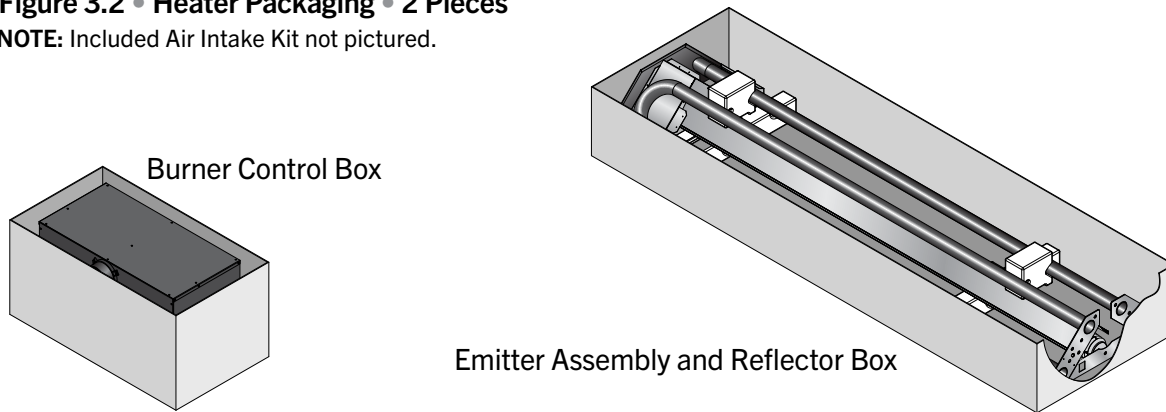

Hanging the Heater

NOTICE

High humidity or saltwater atmospheres will accelerate heater corrosion and reduce useful life. Do not install the heater in locations where water (in the form of rain, drips, or spray) could fall onto the gas ignition components.

⚠ WARNING



Improper suspension of the radiant tube heater may result in collapse and being crushed. Always suspend from a permanent part of the building structure that can evenly support the total force and weight of the heater.



Failure to maintain minimum clearances to combustibles may result in fire and/or explosion, property damage, serious injury, or death. Always maintain minimum clearances.

The suspension of the heater must conform to all applicable codes reference in the safety section and these instructions.

Chart 3.3 • Heater Mounting Requirements and Weights

Model	Overall Unit Length	Shipping Weight	Chain Set Qty.
AVS2-60 [N,P]	112"	160 lbs.	3
AVS2-80 [N,P]	112"	160 lbs.	3

Heater Assembly

Assembly prior to hanging: With this method, the use of two saw horses or a raised table or bench surface is beneficial (the emitter assembly and reflector box may also be used).

- ❶ Lay the emitter assembly across the horses or bench with the exchanger connection hanging bracket extended out over the edge (See Detail 'A') NOTE: Use of the foam shipping blocks will help protect the emitter coating and reflectors.
- ❷ Install the tube flange gaskets onto the corresponding studs on the burner control box.
- ❸ Align the burner control box studs with the holes located on the emitter plates and the hole on the exchanger connection hanging bracket.
- ❹ Install seven (7) 5/16 - 18 keps nuts provided, tightening evenly and torque to 20 ft-lb. Insert two (2) #10 x 5/8 screws through the flange support pilot holes (see Figure 3.3).
- ❺ If operating the unit unvented, install the factory supplied vent hood using the 3 screws provided.

Reflector Sub-Assembly

- ❶ On a flat surface, lay out two reflectors parallel to each other.
- ❷ Place U-end reflector end cap at one end and burner reflector end cap at the opposite end with the “over/under tabs” facing the reflector.
- ❸ Move the reflector end caps into the reflector ends while aligning the “over tabs” (larger tabs with holes) over the top of the reflector and the “under tabs” (smaller tabs with no holes) under the reflector (see Detail B). This can be achieved by squeezing the reflector slightly to fit into the end cap.
- ❹ Properly secure reflector end caps to reflectors using #8-1/2” screws through the hole into the reflector, being careful not to strip.
- ❺ Repeat process with the remaining two reflectors.

Figure 3.3 • Heater Assembly

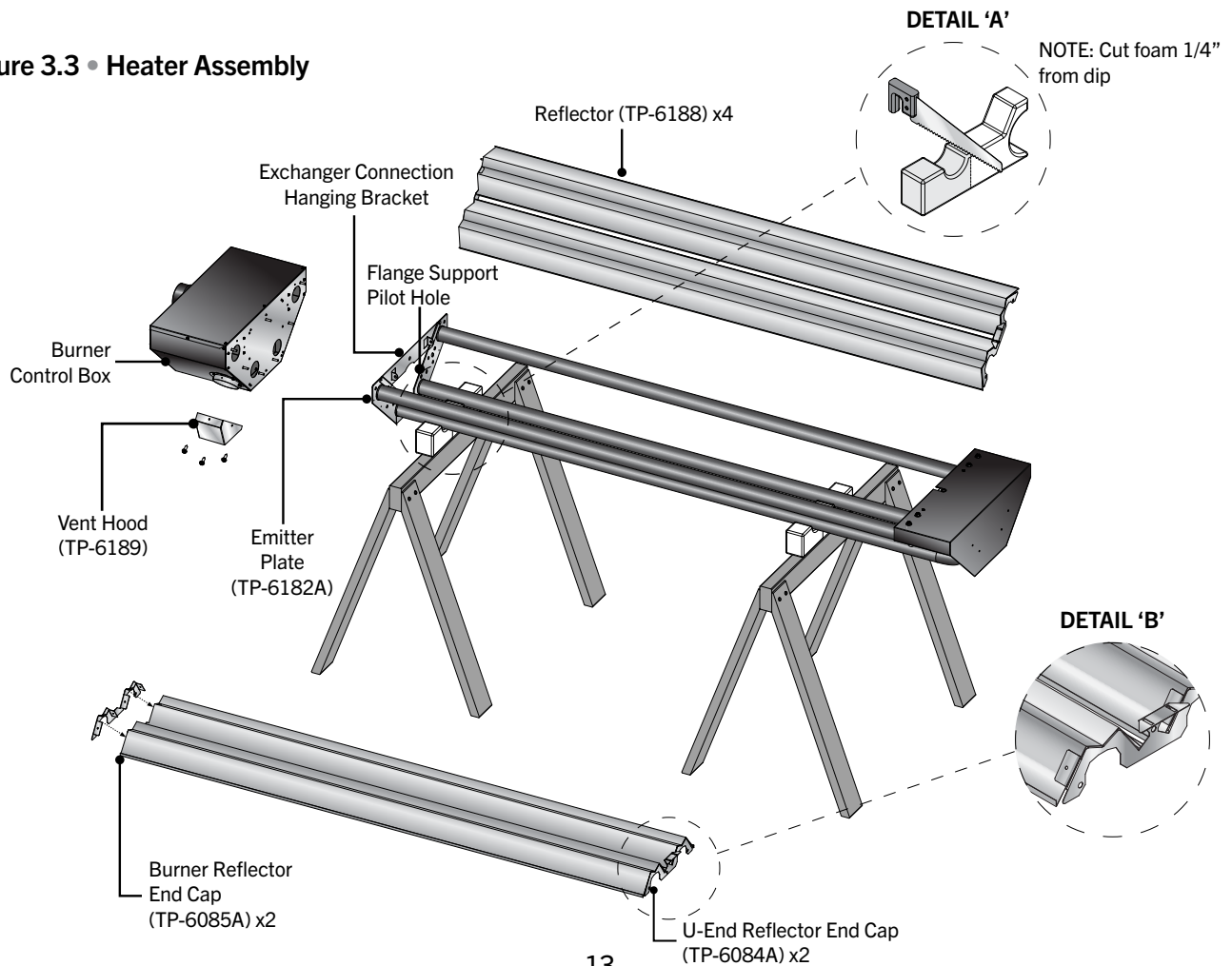

Installing the Reflector Assembly

NOTE: Prior to installing the reflector, relocate the saw horses to support the burner control box and the tubes beneath the U-end reflector.

- ❶ Align the reflector end cap tab with slots with the corresponding U-end flange studs (see Detail 'C'-Step 1).
- ❷ Lower the burner box end cap down over the tubes while shifting the reflector assembly towards the U-end. (see Detail 'C'-Step 2).
- ❸ Secure burner reflector end cap with (2) 5/16"-18 keps nuts (see Detail 'D'). **NOTE:** Do not remove the existing nuts on studs. The burner reflector end cap does not have a tab with slots.
- ❹ Secure the U-end reflector end cap using the red shoulder screws provided (see Detail 'E').
- ❺ Repeat process with remaining reflector assembly.

Figure 3.4 • Final Heater Assembly

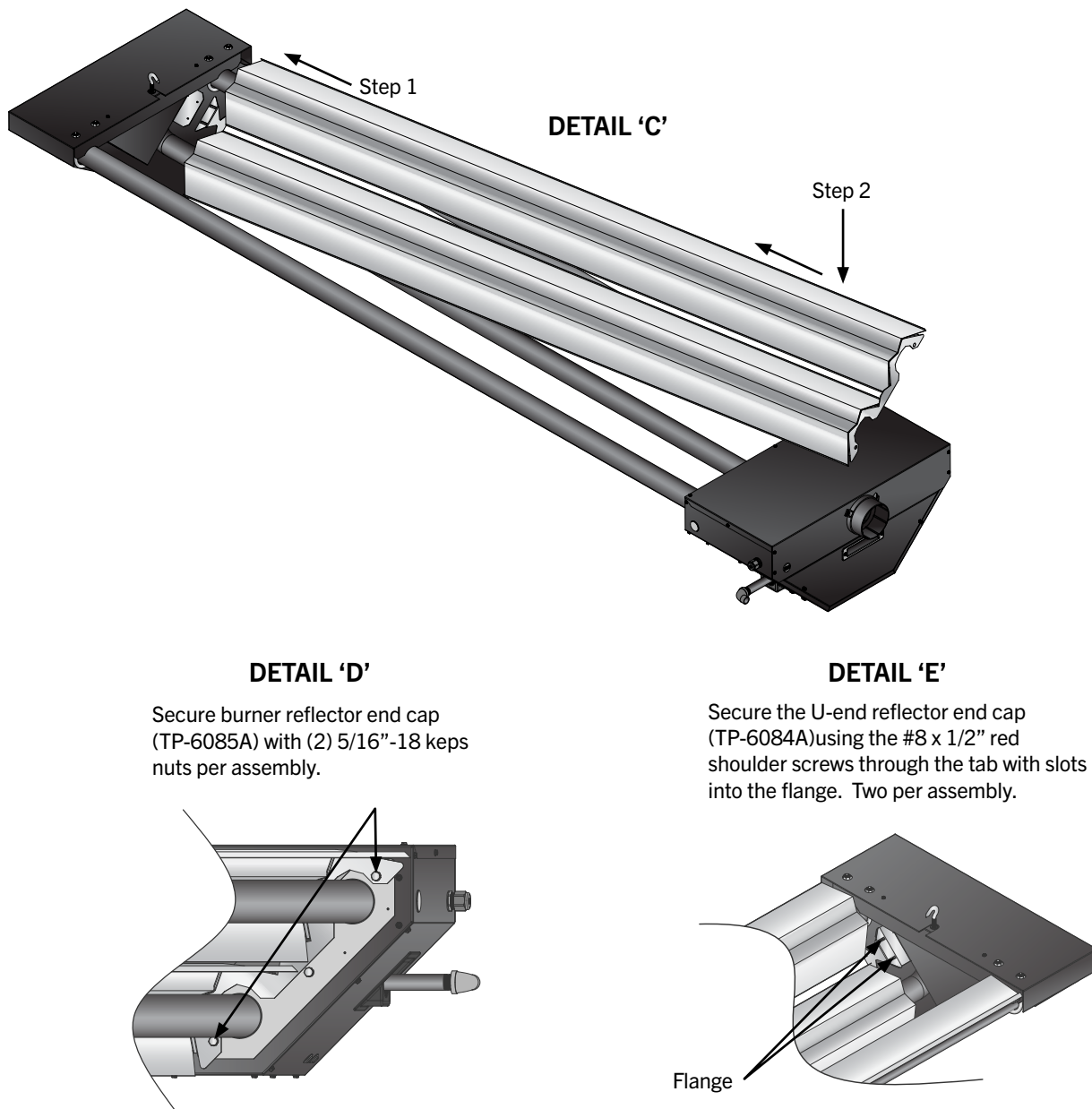

Preparing Points for Hanging

- ❶ Transfer the heater’s three hanging locations to the ceiling where the unit is to be installed and mark hanging points.
- ❷ Prepare mounting surface. If necessary, attach additional support blocks and drill holes (Figure 3.5).
- ❸ Fasten beam clamp, screw hook, or other type of suspension anchor to hanging point.
- ❹ Attach and close S-hook (P/N: S-HOOK) and #1 double-loop chain (P/N: THCS) to anchor. Check that it is securely attached. **NOTE:** Threaded rod and turnbuckles may be used.

NOTE: The unit must be in straight alignment and level. Adjust chain lengths until radiant tubing is level and equal weight distribution is achieved. Chains must be straight up and down. Do not install chains at an angle as this can result in tube warpage or separation.

Figure 3.5 • Hanging Types

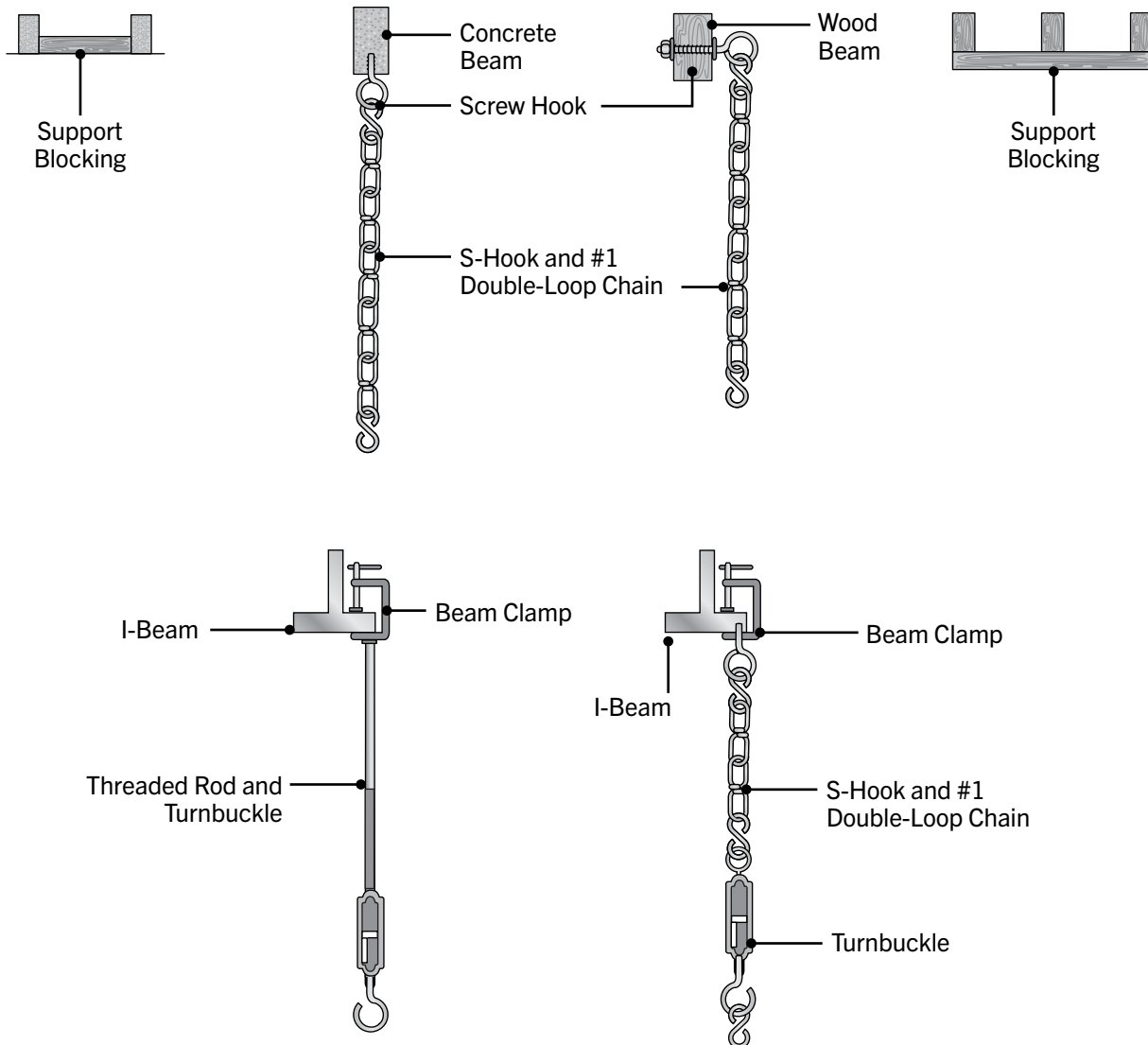

Hanging the Pre-Assembled Unit

- 1 Raise the assembled unit from assembly station to prepared hanging location. **NOTE:** This can be done manually or with a winch system.
- 2 Attach two chains to exchanger connection hanging bracket (TP-6079). Secure S-hooks.
- 3 Attach the third chain located furthest from the gas and electrical connections to the reflector end assembly (TP-6090) and secure S-hook.
- 4 Raise or lower the unit to desired mounting height.

Figure 3.6 • Hanging the Heater

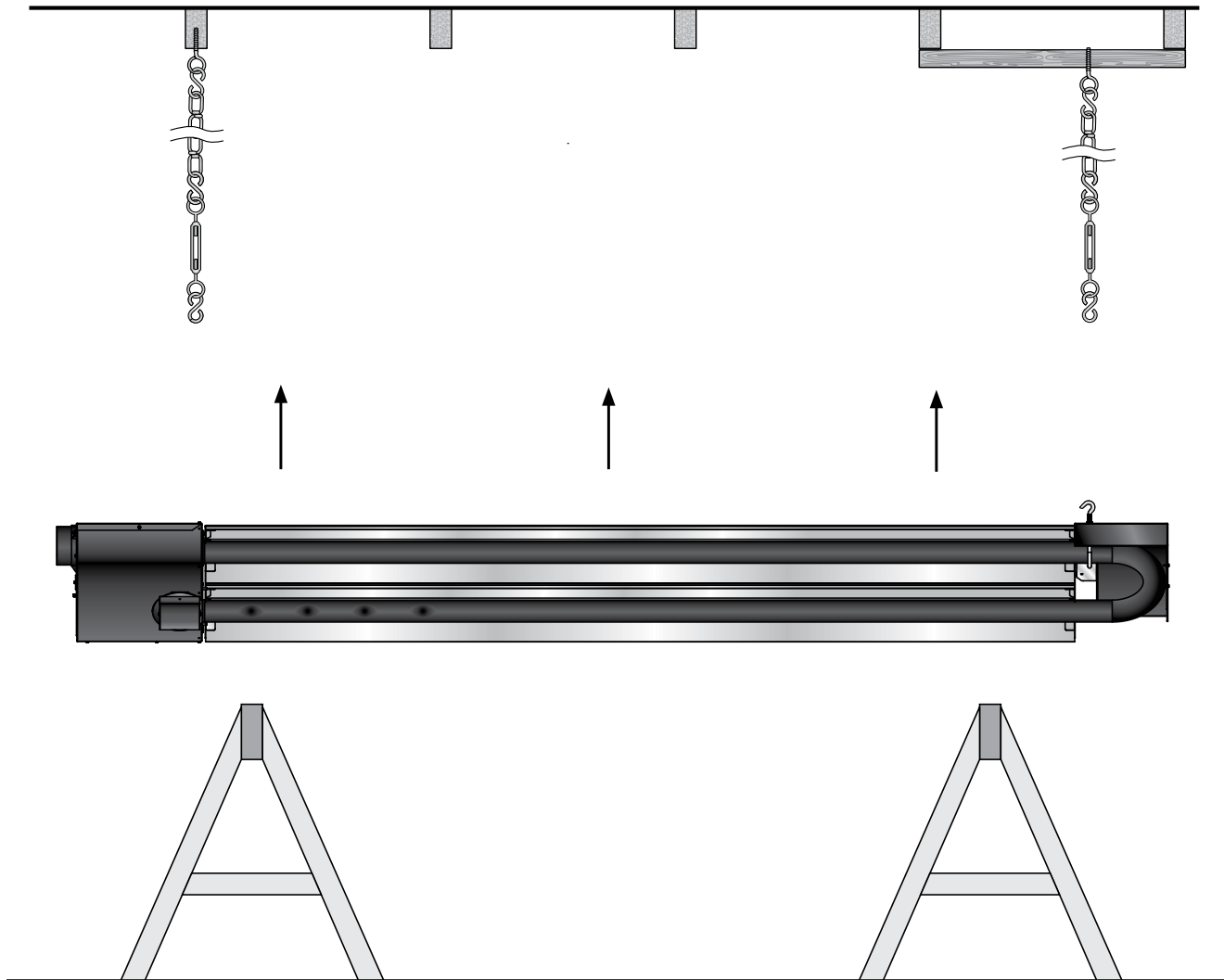

Figure 3.7 • Hanging the Heater - Side View

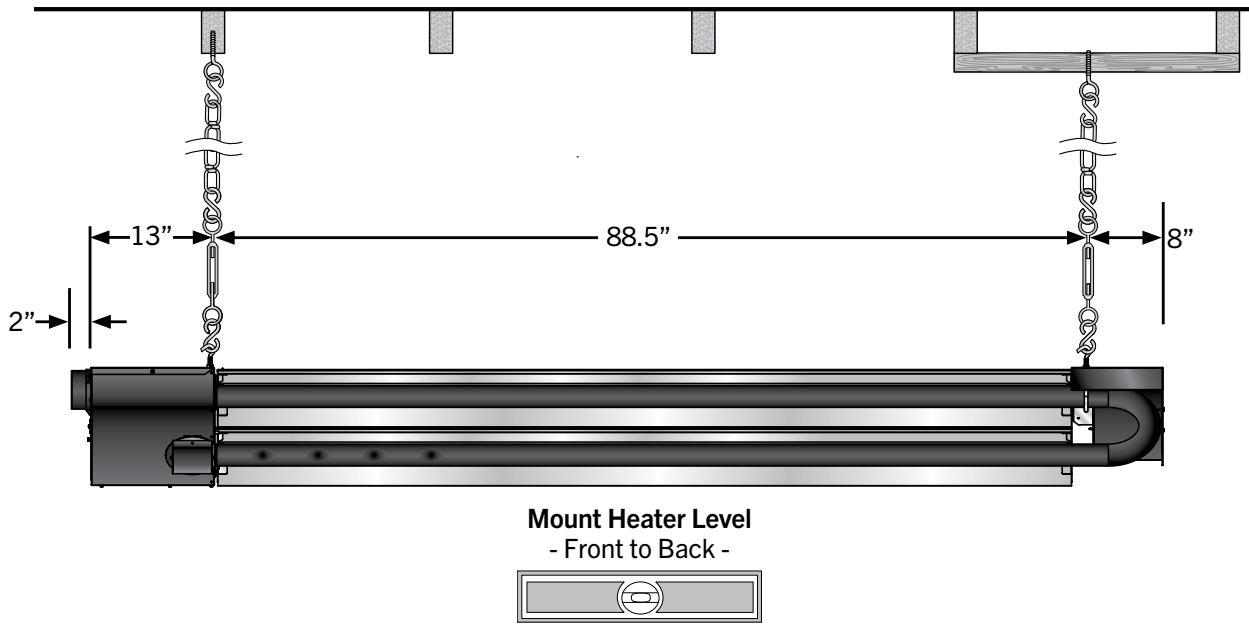

Figure 3.8 • Hanging the Heater
- Burner Box Back View

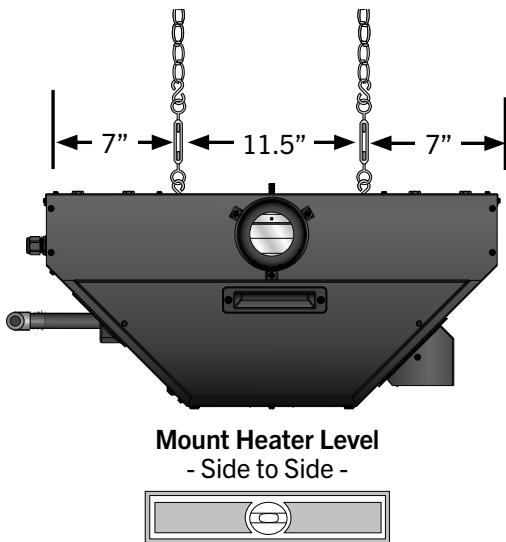
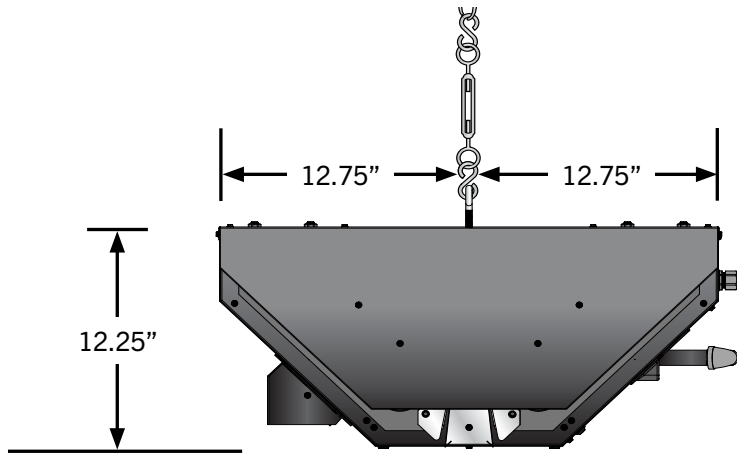

Figure 3.9 • Hanging the Heater
- Exhaust End View



Final Check List

- ❶ Check the unit for level across the length (Figure 3.7).
- ❷ Check the unit for level across the width (Figure 3.8).

Venting

When venting the AVS2 series tube heater, it must be vented as described here to properly direct flue gases from the unit to the outside atmosphere. The venting can terminate vertically through the roof (up) or horizontally through a sidewall (sideways).

Follow these guidelines and all applicable codes for all models prior to installing the vent material. Local codes may vary.

In the absence of local codes:

United States: Refer to NFPA 54/ANSI Z223.1 (latest edition), National Fuel Gas Code.

Canada: Refer to CAN/CSA B149.1 Natural Gas and Propane Installation Code

⚠ WARNING



Insufficient ventilation and/or improperly sealed vents may release gas into the building which could result in health problems, carbon monoxide poisoning, or death.

Improper venting may result in fire, explosion, injury, or death.



Seal vent pipes with high temperature sealant and three (3) #8 sheet metal screws. Vent enclosed spaces and buildings according to the guidelines in this insert manual and applicable national, state, provincial, and local codes.

⚠ WARNING

Do not vent this appliance into another heater's vents or through a masonry chimney.

Do not use dampers in the heater vent pipe.

Single wall vent pipe must not pass through any unoccupied attic, inside wall, concealed space, or floor.

Un-insulated single wall vent pipe must not be used outdoors for venting appliances in regions where winter design temperature is below freezing.

Replacing Existing Equipment

If the heater is replacing existing equipment and using an existing vent system, inspect the venting for proper size and horizontal pitch as directed in these instructions and the latest edition of the National Fuel Gas Code, ANSI Z223.1 (NFPA 54) or CSA B149.1 Installation Code. When an existing Category I heater is removed or replaced, the original venting system may no longer be sized to properly vent the attached appliances.

Determine that there is no blockage or restriction, leakage, corrosion, or other deficiencies that can cause hazards. The vent pipe should be corrosion-resistant galvanized steel of a thickness that meets the National Fuel Gas Code. Minimum thickness for connectors varies depending on the pipe diameter. Never vent the AVS2 series with PVC or plastic pipe.

⚠ WARNING



If replacing an existing heater, vents may require re-sizing. Improperly sized venting systems can result in vent gas leakage or condensation. Refer to the National Fuel Gas Code ANSI Z223.1 (NFPA 54) or CSA B149.1 - latest edition. Failure to follow these instructions can result in serious injury or death.

General Venting Requirements

The venting system for AVS2 series heaters may terminate horizontally through a sidewall or vertically through the roof, and may be individually or commonly vented. Configuration of the vent termination determines the category type. All model heaters must be installed in accordance with the requirements of this section, as well as the requirements of its category determination, as described in this manual. To determine your applications category type, review “Vertical Venting (Category I)” and “Horizontal Venting (Category III)” sections of this manual.

All AVS2 Series Model Requirements:

- Exhaust vent pipe must be 4 inch nominal size.
- Use vent pipe material that is corrosion-resistant galvanized steel of a thickness that meets the National Fuel Gas Code.
- Do not exceed a maximum vent length of 30 feet.
- Maintain a minimum vent length of 3 feet.
- Maintain a minimum of 12 inches of straight pipe from the flue outlet before any directional changes are made in the venting system.
- Have all vent pipe seams or connectors sealed with high temperature silicone sealant approved for at least 550°F (field supplied) and fastened together with at least three (3) corrosion resistant sheet metal screws (field supplied).
- Maintain a 6 inch clearance around all single wall vent pipe from any combustible materials. For double-wall type B vent or Duravent PVP venting, follow the vent manufacturer’s clearances to combustibles.
- The equivalent length for a 4 inch 90° elbow is 5 feet.
- Avoid using more than two 90° directional changes in the venting system.
- Suspend and secure all horizontal runs in a manner consistent with local codes and in such a way that the vent system is supported to prevent sagging.
- Vent termination must maintain a minimum distance of 6 feet from any mechanical air supply inlet.
- The vent terminal must be installed to prevent any blockage by snow and protect building material from degradation by flue gases.
- Consult NFPA ANSI Z223.1 Gas Vent Termination criteria for vents that terminate on a roof pitch that exceeds 9:12.
- **Canada:** Vents must terminate a minimum of 3 feet from a window or door that may be opened, and a non-mechanical air supply inlet or combustion air inlet into the building.

When possible, avoid venting through an unconditioned space. Venting through an unconditioned space promotes condensation. When venting through an unconditioned space is unavoidable, or if the unit is installed in an area that is prone to condensation, insulate venting runs greater than 5 feet to minimize the production of condensation. Inspect for leakage prior to insulating the venting and only use insulation that is non-combustible with a temperature rating of not less than 550°F.

When venting pipe passes through a combustible interior wall or floor, a metal thimble with a diameter 4 inches greater than the vent pipe diameter must be used. If there is 6 feet or more of vent pipe prior to passing through the combustible wall or floor, then the metal thimble need only be 2 inches greater than the vent pipe diameter. If a metal thimble is not used, all clearances to combustibles from the vent pipe must be 6 inches. When permitted, type B vent or Duravent PVP venting may be used for the last section of vent pipe to reduce the required clearances to combustibles when passing through a combustible wall or floor. When using type B vent or Duravent PVP venting, follow the manufacturer's recommended clearances to combustibles. Any material used to close or insulate the opening must be non-combustible.

Vertical Venting (Category I)

An appliance that operates with a non-positive vent static pressure and with a vent gas temperature that avoids excessive condensate production in the vent is said to be 'Category I'. The AVS2 series heater is considered a Category I appliance if the venting system meets all of the following criteria:

- The vent system terminates vertically (up).
- The length of the horizontal portion of the vent run is less than 75% of the vertical rise length. (e.g.- If the vertical vent height is 10 feet, the horizontal run is less than 7 ½ feet).
- The vent terminates a minimum of 5 feet above the vent connection on the unit.
- Horizontal venting sections of the vent pipe must be installed with an upward slope from the appliance at a pitch of ¼ inch per foot.

For vertical vent termination, the venting must comply with all parts of this section, in addition to the requirements of the general venting.

Category I (Vertical) venting is venting at a non-positive pressure. An appliance vented as a Category I is considered a fan-assisted appliance and the vent system does not have to be 'gas tight'.

Vent Locations and Clearances:

- Separate air intake duct from vent pipe by a minimum of 4 feet by placing vent pipes higher than adjacent air intake ducts.
- Utilize a listed type B vent termination cap.
- Vent adapter (P/N: TP-6076A) and vent collar (P/N: TP-6075A) must be used when venting through the roof.
- The vent terminal must extend a minimum of 2 feet above the roof.
- Vent caps should be located a minimum of 2 feet away from adjoining structures.

All vertically vented heaters that are Category I must be connected to a chimney or vent complying with a recognized standard, or lined masonry (or concrete) chimney with a material acceptable to the authority having jurisdiction. Venting into an unlined masonry chimney is not permitted. Refer to the National Fuel Gas Code and page 19 of this manual.

Use a listed vent terminal to reduce down drafts and moisture in the vent.

Figure 3.10 • Rooftop Venting - Side View

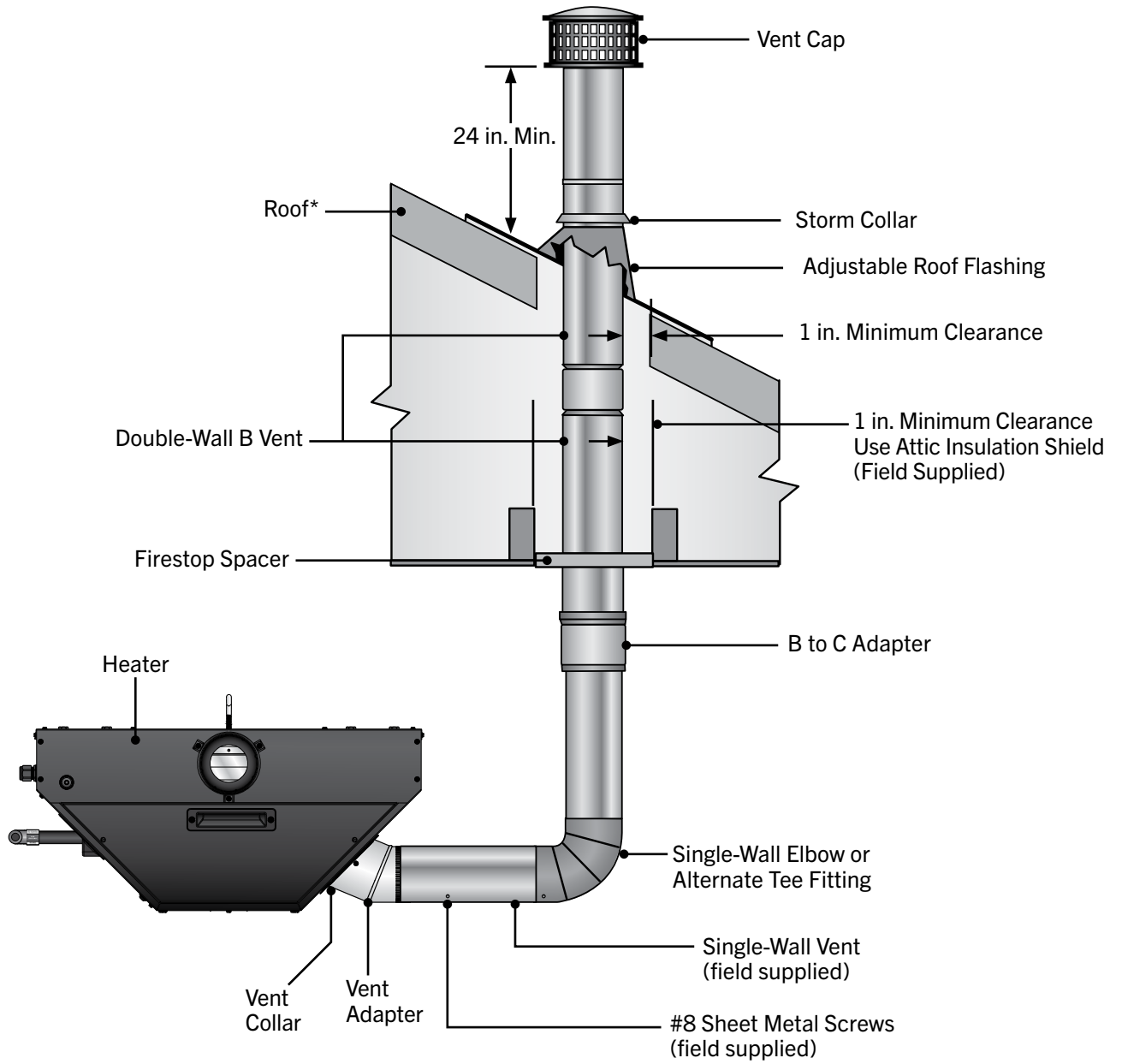

*Consult the NFPA ANSI Z223.1 Gas Vent Termination criteria if roof pitch exceeds 9:12.

Horizontal Venting (Category III)

An appliance that operates with a positive vent static pressure and with a vent gas temperature that avoids excessive condensate production in the vent is said to be “Category III”. The AVS2 series heater is considered a Category III appliance if the venting system meets all of the following criteria:

- The vent system terminates horizontally (sideways).
- The vent terminates vertically, but the length of the horizontal portion of the vent run exceeds 75% of the vertical rise length. (e.g.- If the vertical vent height is 10 feet, the horizontal run is greater than 7 ½ feet).
- The vent terminates below 5 feet of the vent connection on the unit.
- Horizontal venting sections of the vent pipe must be installed with a downward slope from the appliance at a pitch of ¼ inch per foot.

Vent enclosed spaces and buildings according to the guidelines in this manual and applicable national, state, provincial, and local codes.

The venting system must be provided by the installer and should be comprised of single-wall venting materials with a thickness of no less than 26 gauge. All joints must be sealed with a high temperature silicone sealant approved for at least 550°F using a minimum bead of ¼” x ¼”, and fastened with at least three corrosion resistant #8 sheet metal screws evenly spaced.

One continuous section of double-wall B vent or Duravent PVP vent may be used to pass through a combustible wall or barrier, or the installer may continue to use single-wall vent provided a combustible wall thimble is used which provides adequate clearances to combustibles.

All horizontal Category III vents must be terminated with a Simpson-Duravent sidewall vent cap (P/N: SWD-4 for 4” venting).

IMPORTANT! Once all silicone sealant has fully cured according to manufacturer’s instructions, the installer must perform a leak test on the complete venting system. A solution of soap and water may be used to test the venting inside the occupied space. Once the installer has verified the venting system is completely sealed and free of leaks, the heater may be placed into operation.

Vent Locations and Clearances:

- Vent must terminate a minimum of 4 feet below, 4 feet horizontally from, or 1 foot above any window or door that may be opened or gravity air inlet into the building.
- Vent must terminate a minimum of 3 feet above any forced air inlet that is located within 10 feet.
- The bottom of the vent terminate must be located a minimum of 12 inches above grade level and must extend beyond any combustible overhang. Vents adjacent to public walkways must terminate a minimum of 7 feet above grade level.
- The vent cap must be a minimum of 6 inches from the sidewall of the building.
- Vent must be a minimum of 36 inches below or extend beyond any combustible overhang.
- Vent adapter (P/N: TP-6076A) and vent collar (P/N: TP-6075A) must be used when venting through the sidewall.

Never join two sections of double wall vent pipe within one horizontal vent system as it is impossible to verify that inner pipes are completely sealed.

Figure 3.11 • Sidewall Venting Requirements

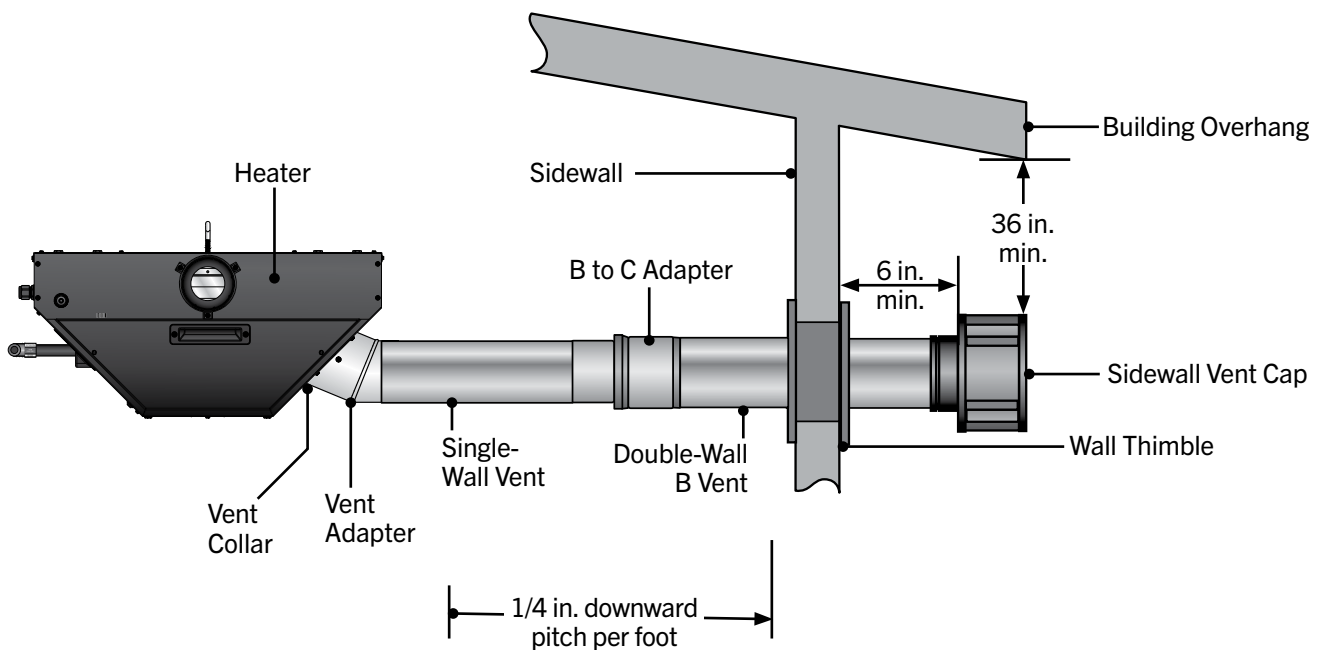

Common Venting (Category I)

The common vent system and all attached appliances must be Category I and must be on the same control device. **Do not operate individually.**

The vent connector should be routed in the most direct route from the units to the common vent. A staggered arrangement or a dual exhaust assembly (P/N: YSM) must be used so by-products of one heater do not flow into the adjoining vent of the other heater.

Where two or more vent connectors enter a common gas vent or chimney flue, the smaller connector shall enter at the highest level consistent with the available head room or clearance to combustible material.

Restrictions within the common vent such as elbows should be minimized. Each elbow installed within the common portion of the vent carrying system reduces the maximum common vent capacity by 10%. Refer to NFPA 54 IFEC tables 11.2 and 11.3 for capacity.

The vent connector capacities allow for the use of two 90° directional changes. For each additional required elbow, the vent connector capacity is reduced by 10%.

The common vent cross sectional area must be equal to or greater than the largest vent connector cross sectional area.

Vent adapter (P/N: TP-6076A) and vent collar (P/N: TP-6075A) must be used when common venting.

Figure 3.12 • Common Rooftop Venting - Side View

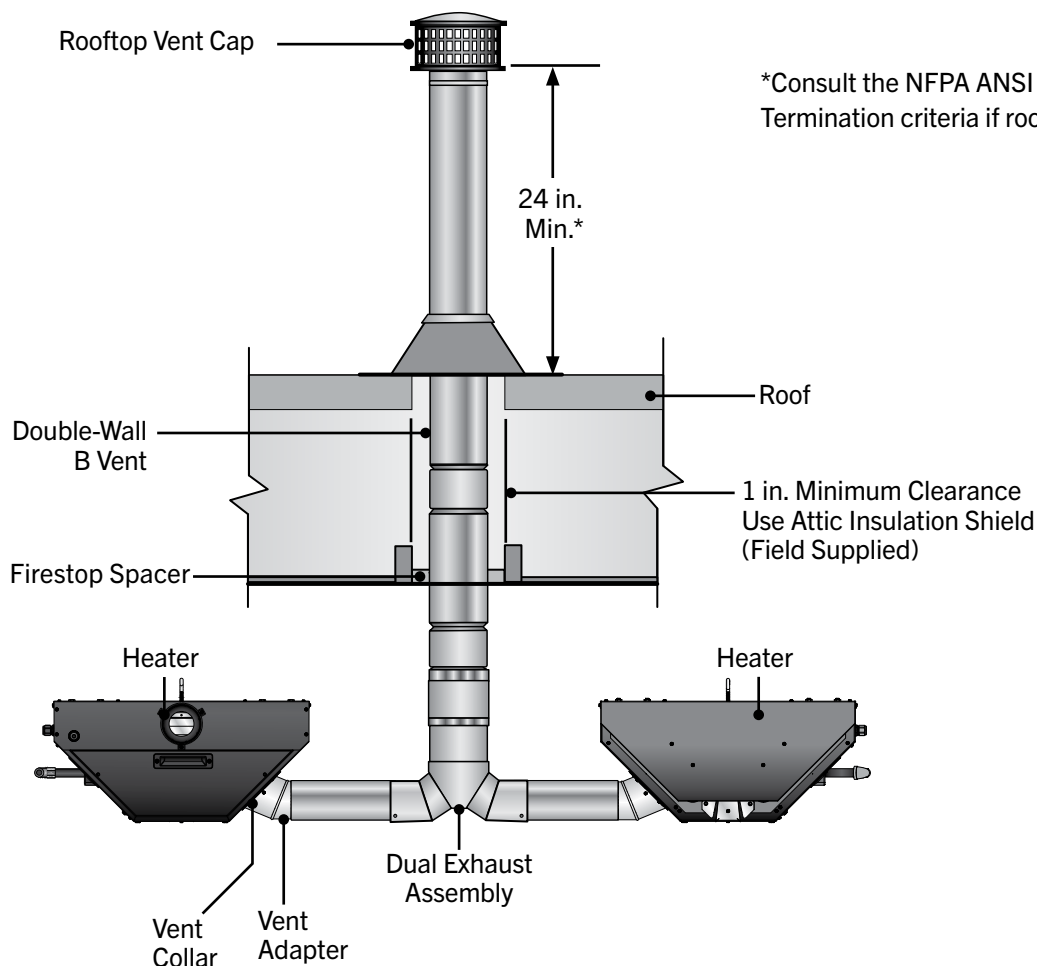

Unvented Operation

⚠ WARNING



Not for residential use. The use of unvented radiant tube heaters in residential indoor spaces may result in property damage, serious injury, or death. Use unvented operation in commercial and industrial installations with proper ventilation rates only.

When using an unvented configuration (agricultural use only), consider the following:

- A factory supplied vent cap/diffuser (P/N: TP-6189) **must** be used.
- Where unvented heaters are used, natural or mechanical means **must** be provided to supply and exhaust a minimum of 4 CFM per 1,000 BTU/h (0.38 m³/kW) input of installed heaters.

NOTE: Gravity or mechanical means may be used to accomplish the air displacement. Local codes may require that the mechanical exhaust system be interlocked with the electrical supply line to the heaters, enabling both to function simultaneously.

- Exhaust openings for removing the flue products must be located above the level of the heater(s).

Figure 3.13 • Minimum End Clearances

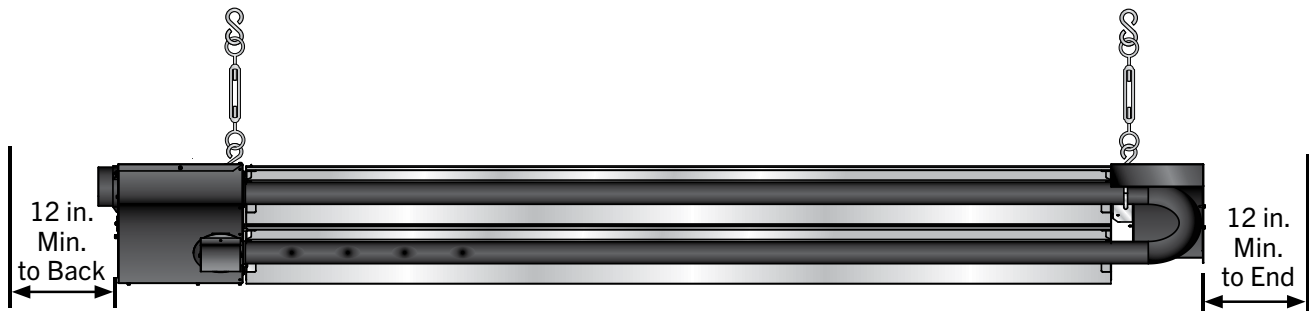

Combustion Air Requirements

Combustion air may be supplied to the heater by indoor or outdoor means.

If using combustion air intake from indoors, the required volume of the space must be a minimum of 50 ft³ per 1,000 BTU/h (4.8 m³/kW) unless the building is of unusually tight construction. If the building is of unusually tight construction with air infiltration rates of less than 0.40 air changes per hour, outside combustion air is typically needed unless the sheer size of the building allows otherwise. Contact the factory for further determination of air infiltration rates.

Non-contaminated outside air for combustion must be ducted to the heater if any of the following apply:

- Chemicals such as chlorinated or fluorinated hydrocarbons (typical sources are refrigerants, solvents, adhesives, degreasers, paints, paint removers, lubricants, pesticides, etc.).
- High humidity.
- Contaminants such as sawdust, welding smoke, etc.
- Negative building pressure.
- Unusually tight construction where there is an air infiltration rate of less than 0.40 air changes per hour.

Combustion air intake may be located on either the sidewall or roof (see figures 3.14 - 3.17).

Figure 3.14 • Vertical Attic Air Supply for Single Heater Intake
- Side View

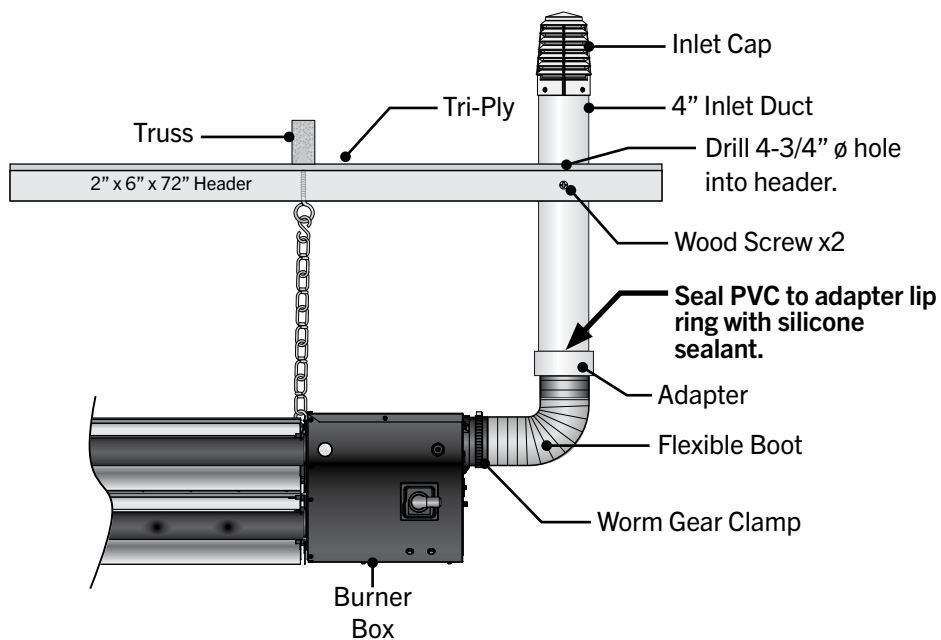

Figure 3.15 • Optional Vertical Outside Air Supply for Single Heater Intake - Side View

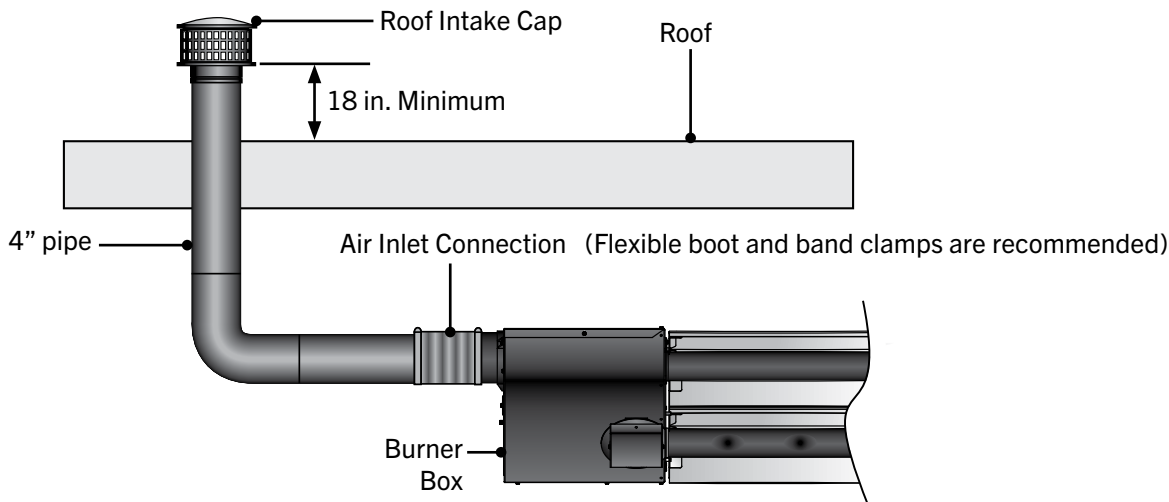

Figure 3.16 • Horizontal Outside Air Supply for Single Heater Intake - Side View

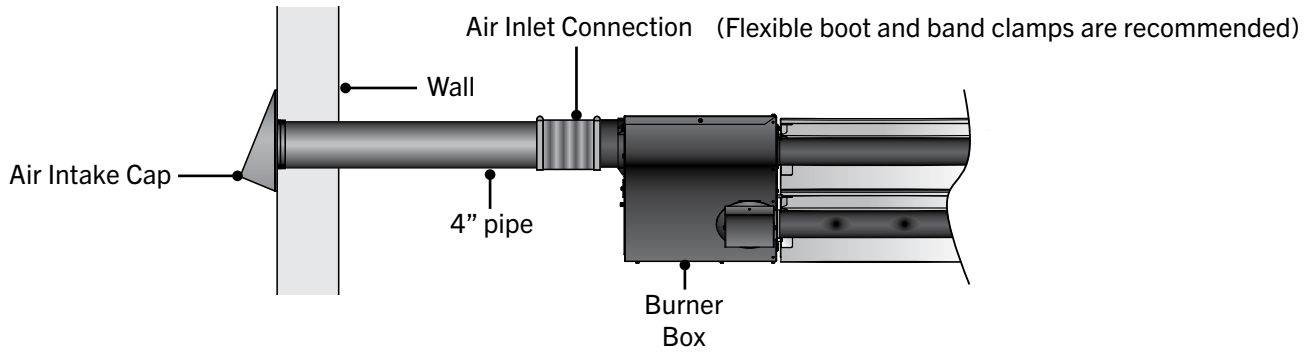
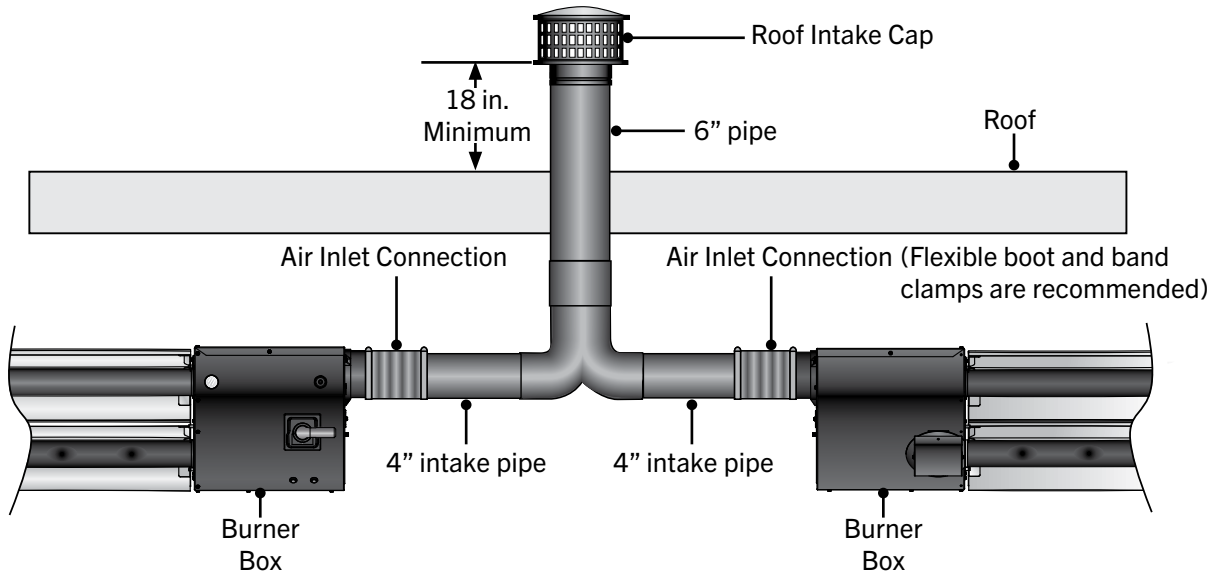

Figure 3.17 • Vertical Outside Air Supply for Common Heater Intake - Side View



NOTE: Common intake heaters must share the same thermostat.

Guidelines:**Chart 3.4 • Limitations for Length and Size of Combustion Air Intake Duct**

Single Heater Intake		Dual Heater Intake	
Air Intake Duct Size	Max. Intake Length	Duct Size	Max. Intake Length
4 in.	20 ft.	4 in.(single)/6 in.(dual)	20 ft.
5 in.	30 ft.	4 in.(single)/8 in.(dual)	30 ft.
6 in.	40 ft.	Consult factory for longer intake lengths.	

General

- No more than two (2) 90° elbows are allowed.
- Allow for expansion. Use a 4 in. flexible hose to connect the duct to the burner control box.
- In humid environments, use insulated duct, PVC pipe, or DWV (drain waste vent) to prevent condensation on the outer surface.
- A factory approved wall intake cap (P/N: WIV-4) must be used with horizontal outside intake ducts. The wall intake cap (P/N: WIV-4) must be installed to prevent blockage. Locate the intake where dirt, steam, snow, etc. will not contaminate or clog the intake screen.
- Separate air intake duct from vent pipe a minimum of 4 ft. Also, place vent pipe higher than adjacent air intake duct.

Gas Supply

The gas supply to the tube heater must be connected and tested in accordance with national, state, provincial, and local codes along with guidelines in this manual. In the United States refer to the latest edition of the ANSI Z223.1 (NFPA 54) Standard and in Canada refer to the latest edition of the CAN/CGA B149.1 Standard.

Supply gas piping to the unit should conform with the local and national requirements for type and volume of gas handled, and pressure drop allowed in the line. Avoid pipe sizes smaller than 1/2". The installation must conform with local building codes or, in the absence of such codes, the National Fuel Code (NFPA 54) and in conjunction with ANSI Z21.24/CSA 6.10 "Connectors for Gas Appliances".

⚠ WARNING

Improperly connected gas lines may result in serious injury and death, explosion, poisonous fumes, toxic gases, or asphyxiation. Connect gas lines in accordance to national, state, provincial, and local codes.

Gas pressure to the appliance controls must never exceed 1/2 PSI (14" W.C.). Damage to the controls may result.

⚠ CAUTION

Gas lines should be purged of air as described in ANSI Z223.1 (NFPA 54) or CSA-B149.1— latest edition. Installation of the piping must also conform with the local building codes, or in the absence of local codes, with the latest edition of the National Fuel Gas Code (NFPA 54). In Canada, installation must be in accordance with CSA-B149.1

NOTICE

The total input to the appliance must fall within +/- 5% of the rated input as indicated on the rating plate. Otherwise the heat exchanger may prematurely fail.

IMPORTANT! The heating system will expand and contract during operation. **Allowances for expansion must be made between the connection to the heater and the gas supply.** A flexible gas connection of approved type is required. Flexible stainless steel gas connectors installed in one plane, and without sharp bends, kinks, or twists is recommended.

IMPORTANT! Before connecting the gas supply to the burner control box:

- Verify that the heater’s gas type (as listed on the rating plate) matches that of your application and the installation complies with national and local codes and requirements of the local gas company.
- Unless otherwise noted on the rating plate, this infrared heater is designed and orificed to operate on standard BTU gas. Contact the factory if utilizing non-standard BTU gas.
- Check that the gas piping and service has the capacity to handle the total gas consumption of all heaters being installed, as well as any other gas appliances being connected to the supply line.
- Check that the main gas supply line is of proper diameter to supply the required fuel pressures.
- If utilizing used pipe, verify that its condition is clean and comparable to a new pipe. Test all gas supply lines in accordance with local codes.

To connect the gas:

! WARNING



Failure to install, operate, or service this appliance in the approved manner may result in property damage, injury, or death. Only trained, qualified gas installation and service personnel may install or service this equipment.

! WARNING



Always use two (2) opposing wrenches to tighten mating pipe connections to prevent excessive torque on the gas valve and manifold pipe. Excessive torque can damage the valve and/or misalign the orifice, resulting in fire, explosion, serious injury, or death.

When connecting piping to the unit, the use of a thread joint compound is required. The thread compound (pipe dope) shall be resistant to the action of propane gas or any other chemical constituents of the gas to be conducted through piping. Use of Teflon® tape is not permitted.

Install ground joint union with a brass seat and a manual shut-off valve adjacent to the unit for emergency shut-off and easy servicing of controls. A 1/8” NPT plugged tap that is accessible for a test gauge connection is also recommended, as illustrated in Figures 3.18 and 3.19 on page 30.

A sediment trap must be installed in the supply line in the lowest spot prior to connecting to the heater. The trap length shall be at least three inches long. Ideally, the trap would be installed as close as possible to the shut-off, as shown in Figure 3.18

The gas outlet must be in the same room as the appliance is installed, and must be accessible. It may not be concealed within or run through any wall, floor, or partition. When installing the heater in a corrosive environment (or near corrosive substances), use a gas connector suitable for the environment. Do not use the gas piping to electrically ground the heater.

Installation of the Gas Line to the Heater

- ❶ Install a sediment trap / drip leg in the supply line at the lowest spot downstream of the gas ball valve. The trap length shall be at least three inches long. Ideally, the trap would be installed as close as possible to the shut off. **NOTE:** For high pressure gas above 14" W.C., a high pressure regulator and ball valve must be utilized and located upstream of the flex connector.
- ❷ Install manual shut off ball valve with optional $\frac{1}{8}$ " NPT Test connection towards the supply line. The manual shut off ball valve must be located within 6 feet of the appliance's service access door.
- ❸ Install the $\frac{5}{8}$ inch flare to $\frac{1}{2}$ " NPT adapter piece downstream of the ball valve as shown in Figure 3.18. This piece is typically included with the flexible gas connector, loosely installed on one of the flare nuts. **NOTE:** Keep flare surfaces clean and free of sealing compounds. Only the pipe threads require sealing compounds.
- ❹ Form the stainless steel flexible connector into a smooth C-shape, allowing approximately 12 inches between the flexible connector's end nuts (see Figure 3.18). The connector must reach from the gas supply to the appliance without stretching, kinking, or twisting.
- ❺ Attach the flexible connector to the $\frac{5}{8}$ " flare adapter on the gas line and the other end to the $\frac{5}{8}$ " flare on the heaters inlet pipe. **DO NOT** connect the connector flare nuts directly to pipe threads. Use only the adapters provided. **DO NOT** kink, twist, or over-torque the connector when installing.

⚠ CAUTION

When using a stainless steel flexible gas connector, **do not** attach the connector nuts directly to the gas pipe supply. Connector nuts must be installed to an approved adapter.

Figure 3.18 • Gas Connection (Flexible Gas Connection shown) - End View

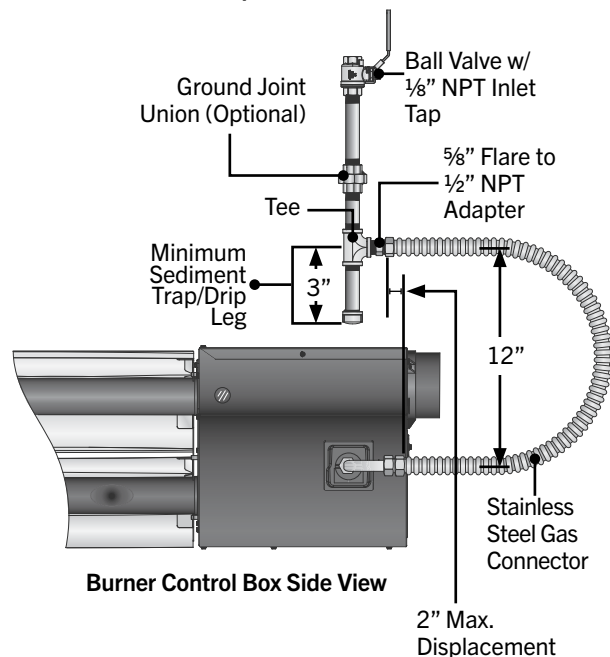
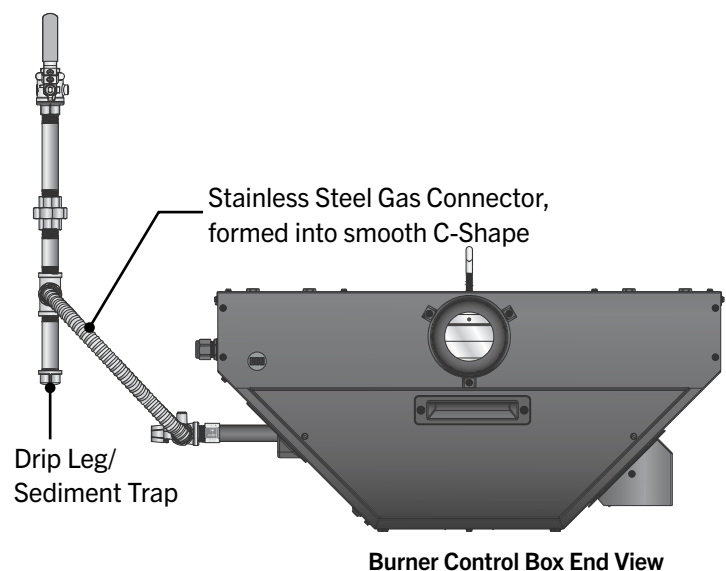

Figure 3.19 • Gas Connection (Flexible Gas Connection shown) - Side View



Note: Ball valve can be located as shown in image or between the flex connector fitting and the manifold pipe protruding from the burner control box.

Refer to Chart 3.5 for natural gas and Chart 3.6 for propane to determine the cubic feet per hour (CFH) required for the type of gas and size of unit to be installed. To determine the proper pipe diameter, use the CFH value and the length of pipe necessary from Chart 3.7. In the case where several units are serviced by the same main gas line, the total capacity (CFH) and length of main must be adequate to service all appliances downstream of this main.

Chart 3.5 • Natural Gas Consumption

Model	Input	Manifold Pressure (Inches W.C.)	Minimum Inlet Pressure (Inches W.C.)	Gas Consumption* (CFH)
AVS2-80N	80,000	3.5	5.0	76.2
AVS2-60N	60,000	3.5	5.0	57.1

* Assumes an average heating value of 1050 BTU/SCF and a Specific Gravity of 0.60.

Chart 3.6 • Propane Gas Consumption

Model	Input	Manifold Pressure (Inches W.C.)	Minimum Inlet Pressure (Inches W.C.)	Gas Consumption* (CFH)	Gallons per Hour*
AVS2-80P	80,000	10.0	11.0	32.0	0.88
AVS2-60P	60,000	10.0	11.0	24.0	0.66

* Assumes an average heating value of 2500 BTU/SCF and a Specific Gravity of 1.53.

Chart 3.7 allows for a 0.3 inch W.C. pressure drop in the supply pressure from the building main to the inlet of the unit. Refer to the chart for the appropriate range of inlet pressures for each gas type. When sizing the inlet gas pipe diameter, make sure that the unit supply pressure can be met after the 0.3 inch W.C. pressure drop has been subtracted from the main pressure. If the 0.3 inch W.C. pressure drop is too high, refer to NFPA 54 or the Gas Engineer’s Handbook for other gas pipe capacities.

Chart 3.9 • Maximum capacity for Schedule 40 Metallic pipe, in CFH

Pipe Length	1/2"		3/4"		1"		1-1/4"		1-1/2"		2"	
	Nat	Prop	Nat	Prop	Nat	Prop	Nat	Prop	Nat	Prop	Nat	Prop
10 feet	132	86	278	182	520	340	1050	686	1600	1046	3050	1993
20 feet	92	60	190	124	350	229	730	477	1100	719	2100	1373
30 feet	73	48	152	99	285	186	590	386	890	582	1650	1078
40 feet	63	41	130	85	245	160	500	327	760	497	1450	948
50 feet	56	37	115	75	215	141	440	288	670	438	1270	830
60 feet	50	33	105	69	195	127	400	261	610	399	1150	752
70 feet	46	30	96	63	180	118	370	242	560	366	1050	686
80 feet	43	28	90	59	170	111	350	229	530	346	990	647
90 feet	40	26	84	55	160	105	320	209	490	320	930	608
100 feet	38	25	79	52	150	98	305	199	460	301	870	569
125 feet	34	22	72	47	130	85	275	180	410	268	780	510
150 feet	31	20	64	42	120	78	250	163	380	248	710	464
175 feet	28	18	59	39	110	72	225	147	350	229	650	425
200 feet	26	17	55	36	100	65	210	137	320	209	610	399

Leak Testing

⚠ WARNING



Testing for gas leaks with an open flame or other sources of ignition may lead to a fire or explosion and cause serious injury or death. Test in accordance with NFPA or local codes.

⚠ WARNING



Gas pressures to the appliance controls must never exceed 14 inch W.C. (½ PSI). Supply pressures greater than 14 inch W.C. can damage the controls, resulting in personal injury, property damage, or death.

Use a soap solution or equivalent for leak testing. Leak testing solution must be non-corrosive, and be rinsed off immediately after the leak test. Never test for leaks with an open flame. Failure to comply could result in personal injury, property damage, or death.

Always leak test final gas assembly for gas leaks according to the procedures outlined in NFPA 54 and all local codes and/or standards.

For leak testing on pressures below ½ PSI

Before leak testing, close the field installed manual shut off valve shown in Figure 3.18 on the supply line to isolate the gas valve from the pressure. **NOTE:** All factory installed gas connections have passed an approved leak test.

For leak testing on pressures above ½ PSI

When leak testing with pressures above ½ PSI (14 inches W.C.), the unit must be isolated from the supply pipe. Close the field installed manual shut off valve, disconnect the supply line to the unit, and temporarily cap the supply line for testing purposes.

Electrical Requirements and Wiring Diagrams

⚠ WARNING



Shock hazard. Disconnect power supply before making wiring connections to prevent electrical shock and equipment damage.

Any original factory wiring that requires replacement must be replaced with wiring material having a rating of at least 600 V, 105°C.

All field installed wiring to the tube heater must be done in accordance with the national, state, provincial, local codes, and to the guidelines in this manual. In the United States, refer to the most current revisions to the Electrical Code ANSI/NFPA 70 and in Canada refer to the most current revisions to the Canadian Electrical Code CSA C22.1 Part 1. The unit must be electrically grounded according to these codes. Line polarity must be observed when making field connections.

Field Wiring Supply Voltage

Before proceeding with electrical connections, ensure that the supply voltage, frequency, phase, and current capacity meet the requirements specified on the rating plate. A dedicated line voltage supply with properly sized wire should run directly from the main electrical panel to the heater. The power to the unit must be protected with a circuit breaker appropriate for the load. The unit must be electrically grounded in accordance with local codes or, in their absence, with the latest edition of the National Electrical Code, ANSI/NFPA 70, and/or the Canadian Electrical Code CSA C22.1, latest edition.

⚠ CAUTION

The power supply to the heater must be within +/- 5% of the voltage rating as indicated on the rating plate of the appliance. If input power does not meet these specifications, contact your utility company.

This heater may be equipped with a supply cord to connect the main power supply. If installed, it is located at the rear of the heater's burner box, and utilizes a grounding prong. This plug must be connected into an appropriate outlet receptacle that is properly installed and grounded in accordance with local codes and ordinances.

⚠ WARNING



Electric Shock Hazard

Do not force the three-prong plug into the grounded outlet, modify the plug, or use an adapter. Never operate this appliance if the cord or plug is damaged.

The grounding receptacle must be installed within 5 feet of the heater's service panel, and located in the space occupied by the appliance. When plugging in the heater, make sure the supply cord is protected from damage, and keep all cords away from the heater's surfaces and out of the clearances to combustibles zones (see page 9). When routing the electrical supply for the unit, ensure that it does not interfere or obstruct the heater's service panel.

Thermostat Connection

NOTE: Different thermostats operate according to their particular features. Refer to the thermostat's specifications for details.

Each AVS2 series heater requires a single stage thermostat rated for 120 VAC to operate.

Figure 3.20 • Field Wiring Diagram • Single Unit Operation

120 V Control Connection

Green: Ground

White: Neutral

Black: 120 V Call for Heat When Energized

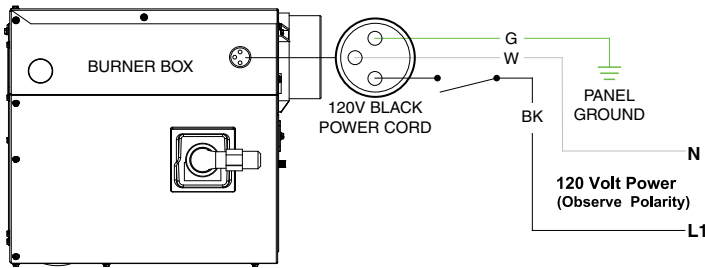

Figure 3.21 • Field Wiring Diagram • Multiple Unit Operation

120 V Control Connection

Green: Ground

White: Neutral

Black: 120 V Call for Heat When Energized

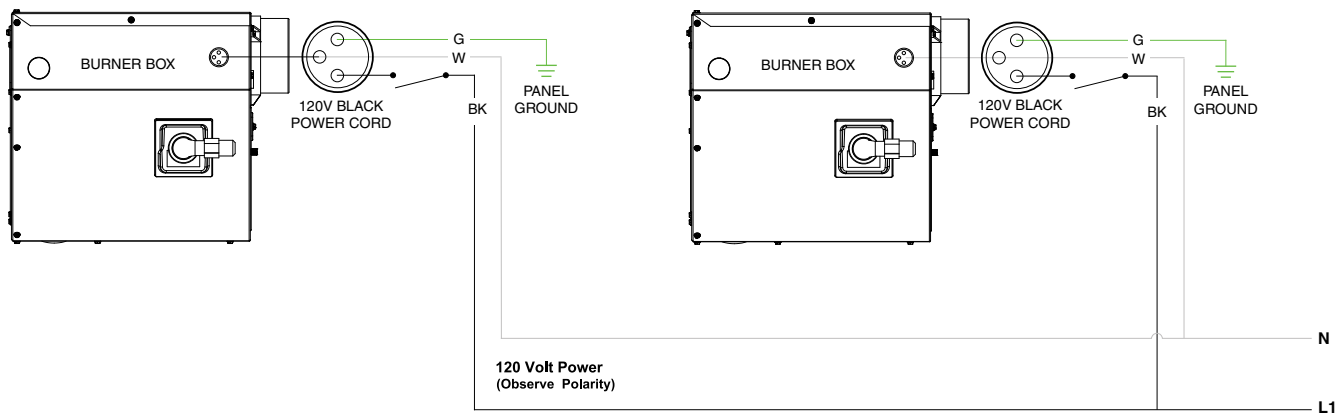

⚠ CAUTION

When utilizing PVC conduit and/or pipe, all clearances to combustibles must be maintained (see pages 7-9). Some materials, including many types of plastic, are subject to degradation at lower temperatures. It is the installer's responsibility to ensure that materials adjacent to the heater are protected from degradation. If you are unsure of the proposed installation, please contact the factory.

Before field wiring this appliance - Check existing wiring; replace if necessary.

NOTE: If any of the original wire supplied with the appliance must be replaced, it must be replaced with wiring material having a rating of at least 600 V, 105° C.

Figure 3.22 • Internal Wiring Diagram

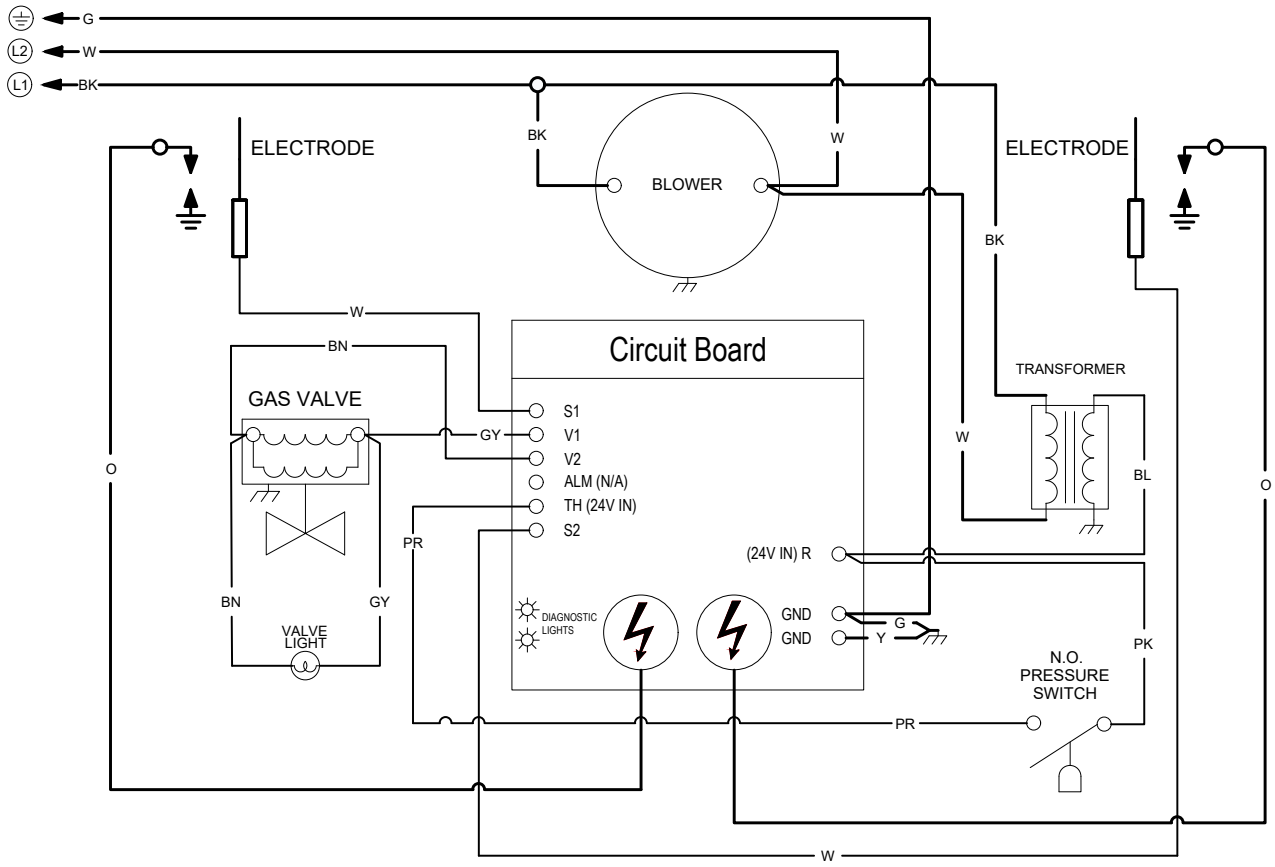

COMPONENT CODES			WIRING COLORS:	WIRING INFORMATION:
⊕ EARTH GROUND	TRANSFORMER	PRESSURE SWITCH		
⏏ CHASSIS GROUND	BLOWER MOTOR	S.P.S.T. RELAY	LINE VOLTAGE: FACTORY STANDARD ——— FACTORY OPTION - - - - - FIELD INSTALLED - - - - -	
Ⓛ LINE VOLTAGE	HOT SURFACE IGNITER	INDICATOR LIGHT		
Ⓛ NEUTRAL	SPARK IGNITER	GAS VALVE	LOW VOLTAGE: FACTORY STANDARD ——— FACTORY OPTION - - - - - FIELD INSTALLED - - - - -	
● WIRE NUT	FLAME SENSOR	QUICK-CONNECT TERM.		

4.0 Operation

⚠ WARNING



This appliance does not have a pilot ignition. It is equipped with an ignition device which automatically lights the burner. **Do not** attempt to light the system by hand.

BEFORE OPERATING, smell all around the appliance area for gas. Be sure to smell next to the floor because some gas is heavier than air and will settle to the floor. Refer to the cover page “If you smell gas” and on the safety label affixed to the heater.

Do not use this appliance if any part has been under water. Immediately contact a qualified service technician to inspect the appliance and to replace any part of the control system and any gas control which has been under water.



Start-Up and Shutdown Procedure

⚠ WARNING



Use only your hand to turn the manual shutoff. Never use tools. If the knob will not turn by hand, don't try to repair it. Call a qualified technician. Force or attempted repair may result in a fire or explosion.

Start-Up Procedures:

- ① **STOP!** Read the safety information above.
- ② Set the thermostat to the lowest setting.
- ③ Turn OFF all electrical power to the appliance.
- ④ Turn manual shutoff clockwise  to “OFF”.
- ⑤ Wait five (5) minutes to clear out any gas. If you smell gas STOP! Follow the safety information found on the cover page under “If you smell gas” and on safety label affixed to the heater. If you do not smell gas, proceed to step 6.
- ⑥ Turn manual shutoff knob counterclockwise  to “ON”.
- ⑦ Turn ON all electrical power to the appliance.
- ⑧ Set thermostat to desired setting.
- ⑨ If the appliance will not operate, follow instructions below to turn OFF gas to the appliance and call your service technician or gas supplier.

Shutdown Procedures:

- ① Set the thermostat to the lowest setting.
- ② Turn OFF all electrical power to the appliance if service is to be performed.
- ③ Turn manual shutoff knob clockwise  to “OFF”. **Do not** force.

⚠ WARNING

This heater must be installed and serviced by trained gas installation and service personnel only.

Do not bypass any safety features or the heater's built in safety mechanisms will be compromised.

Sequence of Operation

Starting Circuit: Upon a call for heat 120 VAC is sent to the blower. The fan and transformer are energized by 120 VAC from the thermostat on controller. Once operational static pressure is achieved, the pressure switch closes, sending power to the ignition module. After a seven-second pre-purge, the spark igniters and the solenoid of the gas valve are simultaneously energized. The trial for ignition is 15 seconds.

Running Circuit: After ignition, the control monitors burner flame through the flame sensors. If sense of flame is lost, the control immediately sparks (identical to the starting sequence). If flame sense is not established within 15 seconds, the heater will attempt two (2) additional ignition sequences before proceeding to lockout mode. The control can be reset by briefly interrupting the power source.

5.0 Maintenance

Troubleshooting Guide

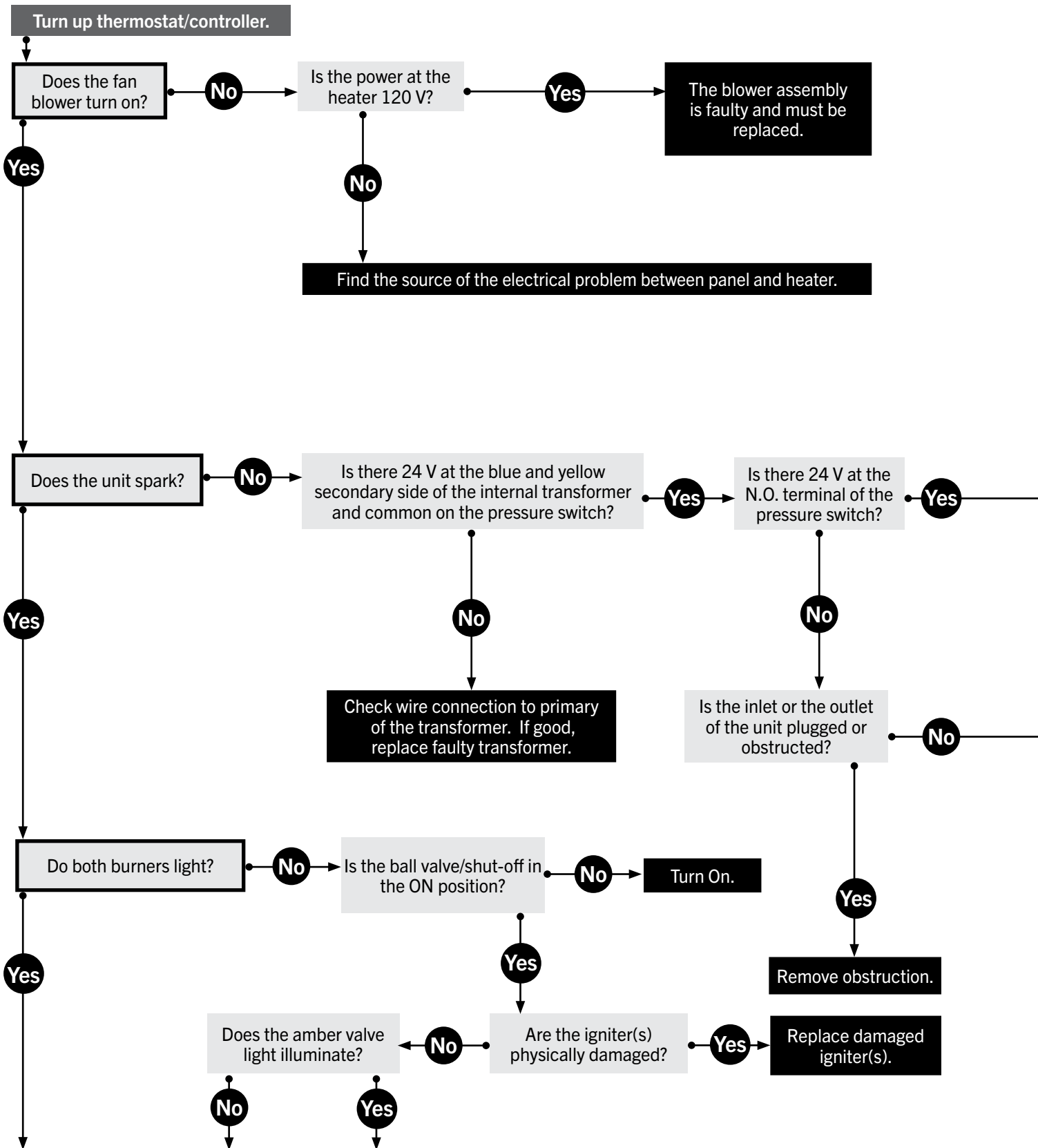

Continued on page 40

NOTICE Bypassing any switch is intended for testing purposes only. Do not leave switch bypassed during normal operation or the heater’s built-in safety mechanisms will be compromised.

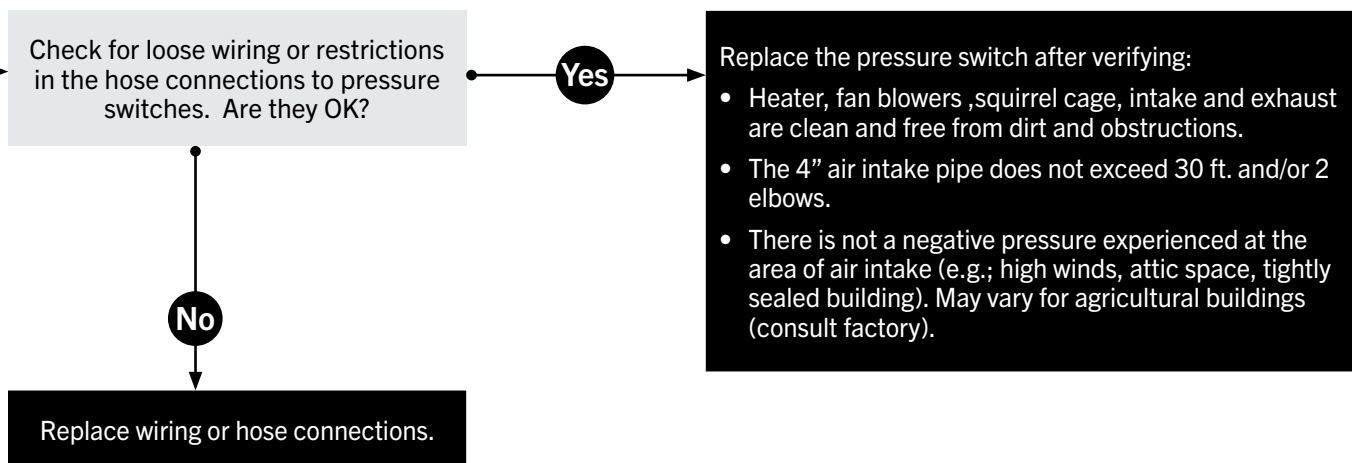
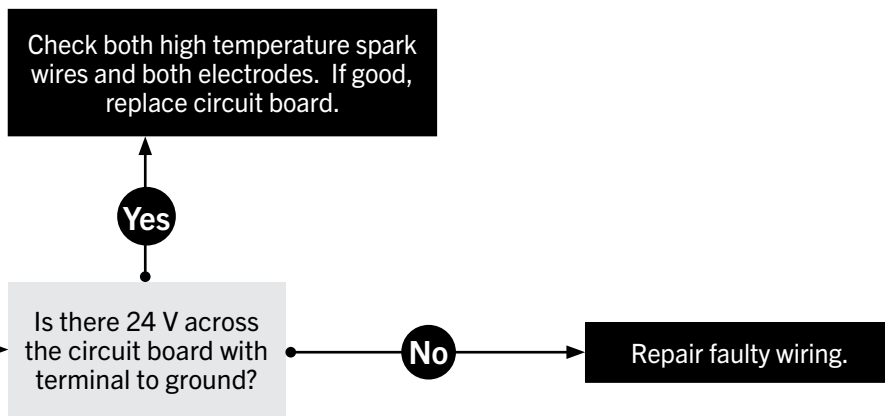
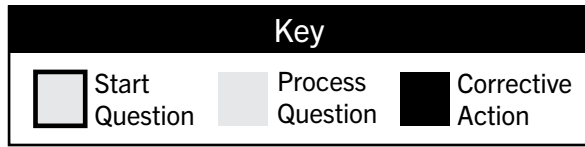

Continued from page 38.

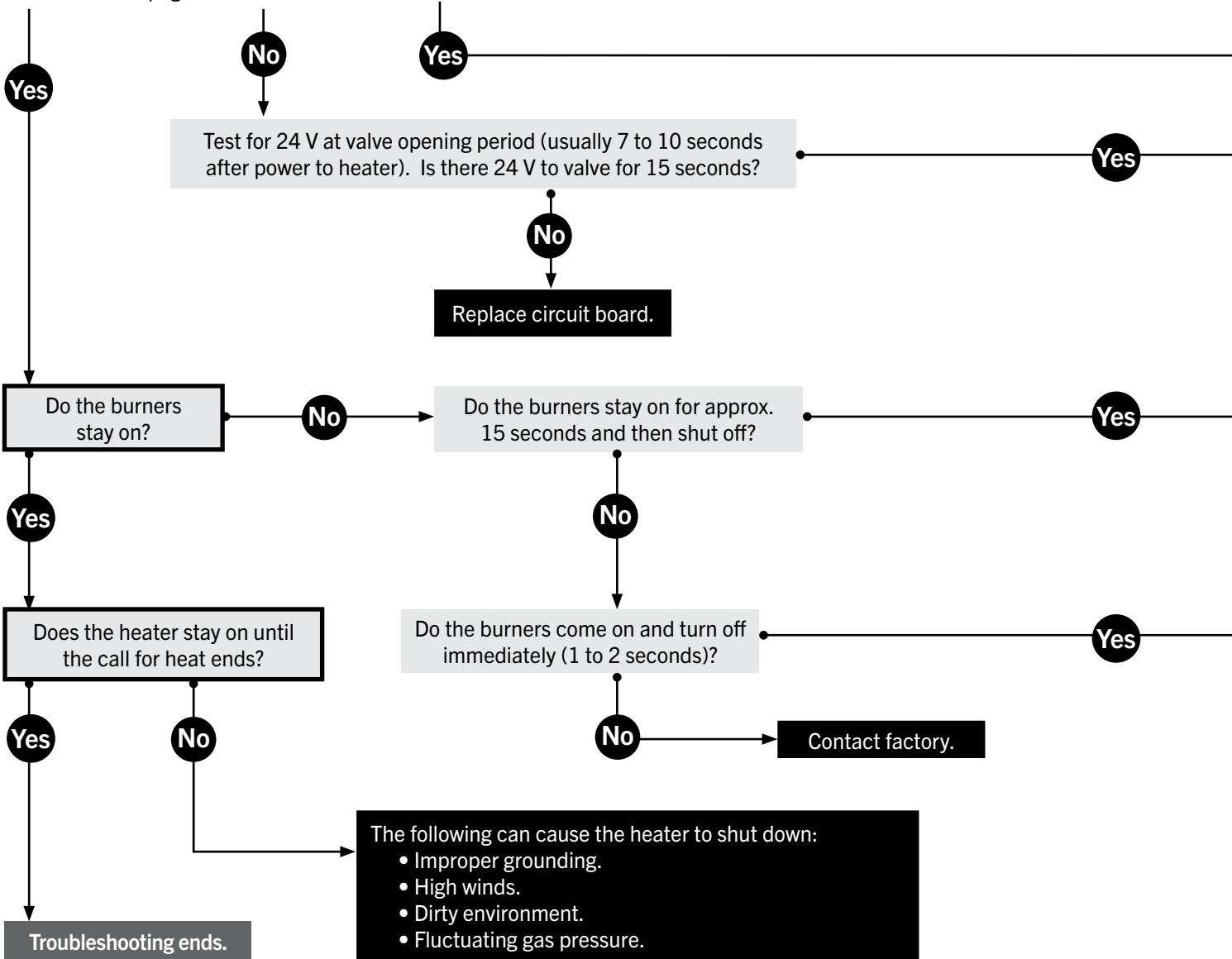

Diagnostic Indicator

LED

- 1 Flash
- 2 Flashes
- 3 Flashes
- 4 Flashes

MODE

- Start up.
- Flame. No call for heat.
- Ignition lockout.
- Valve relay lockout.

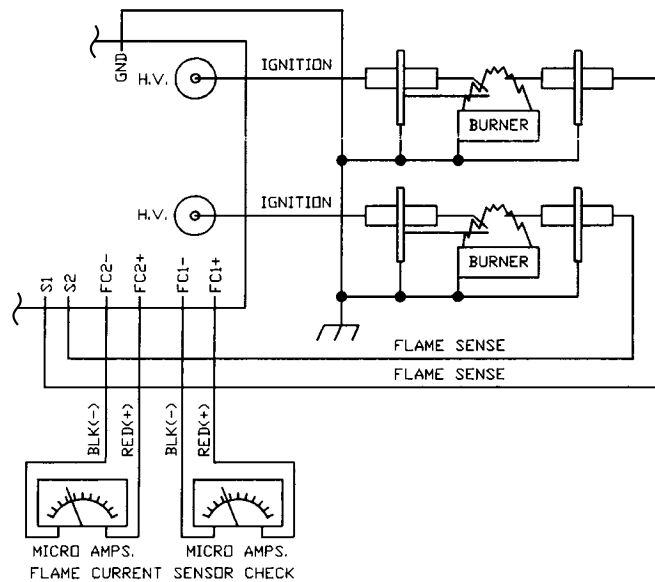

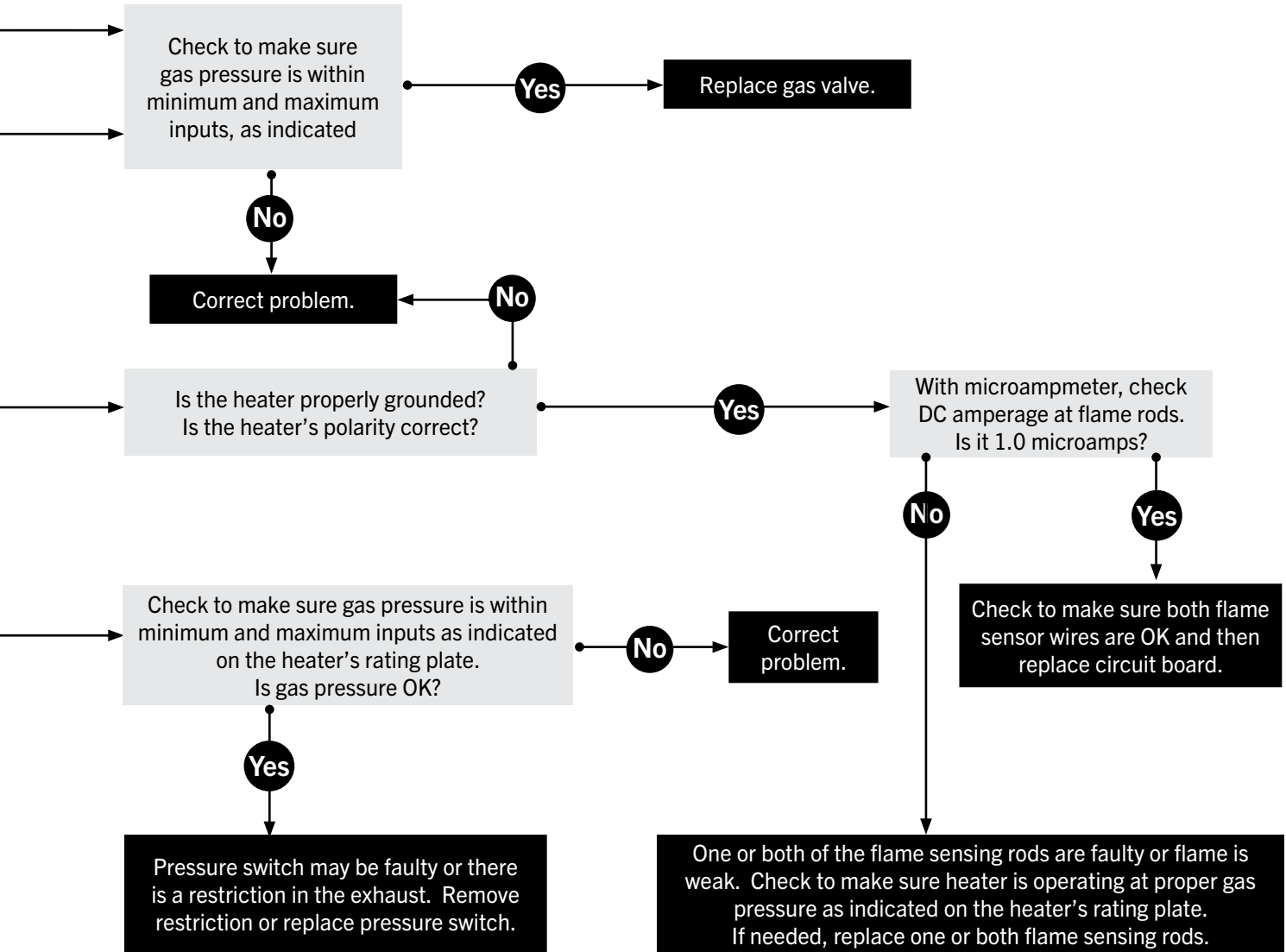

Replacement Parts

Figure 5.1 • Burner Assembly Components

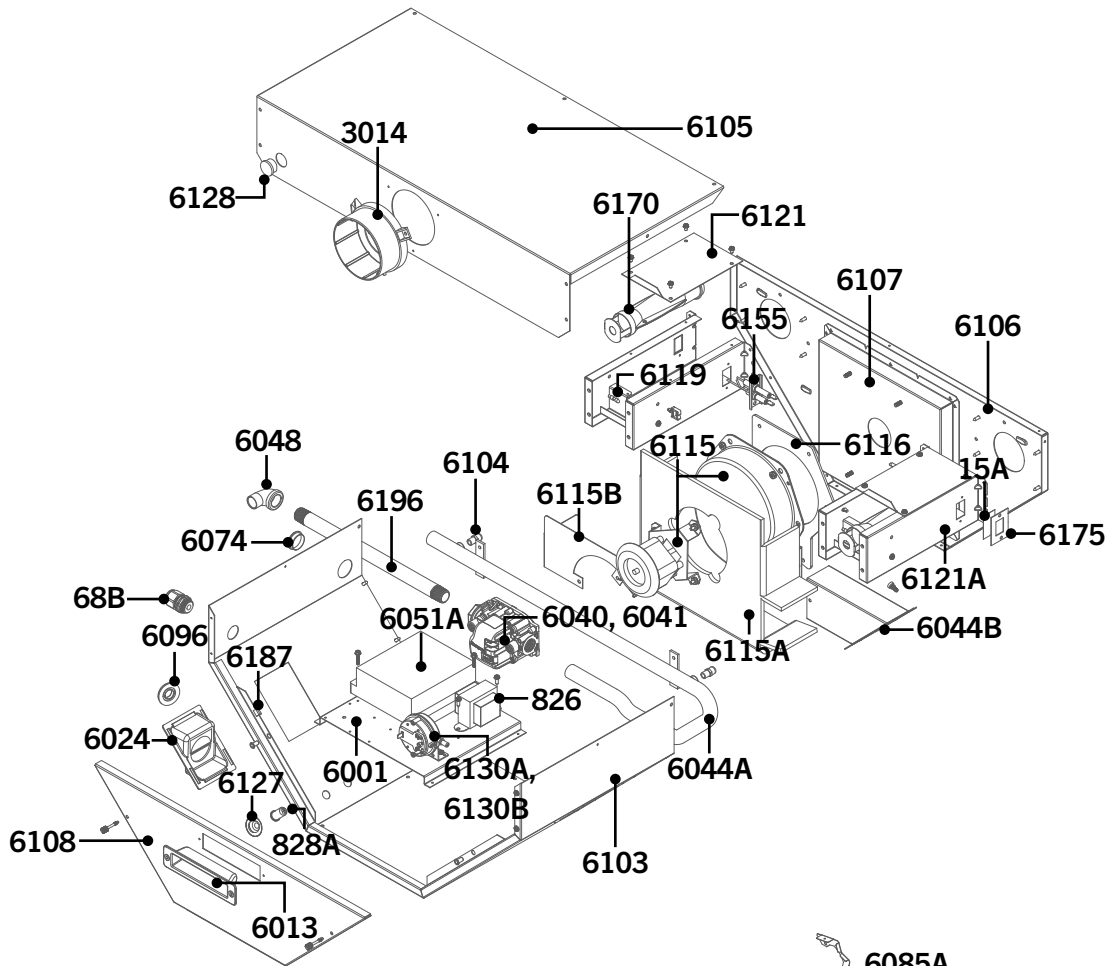

Figure 5.2 • Tube and Reflector Components

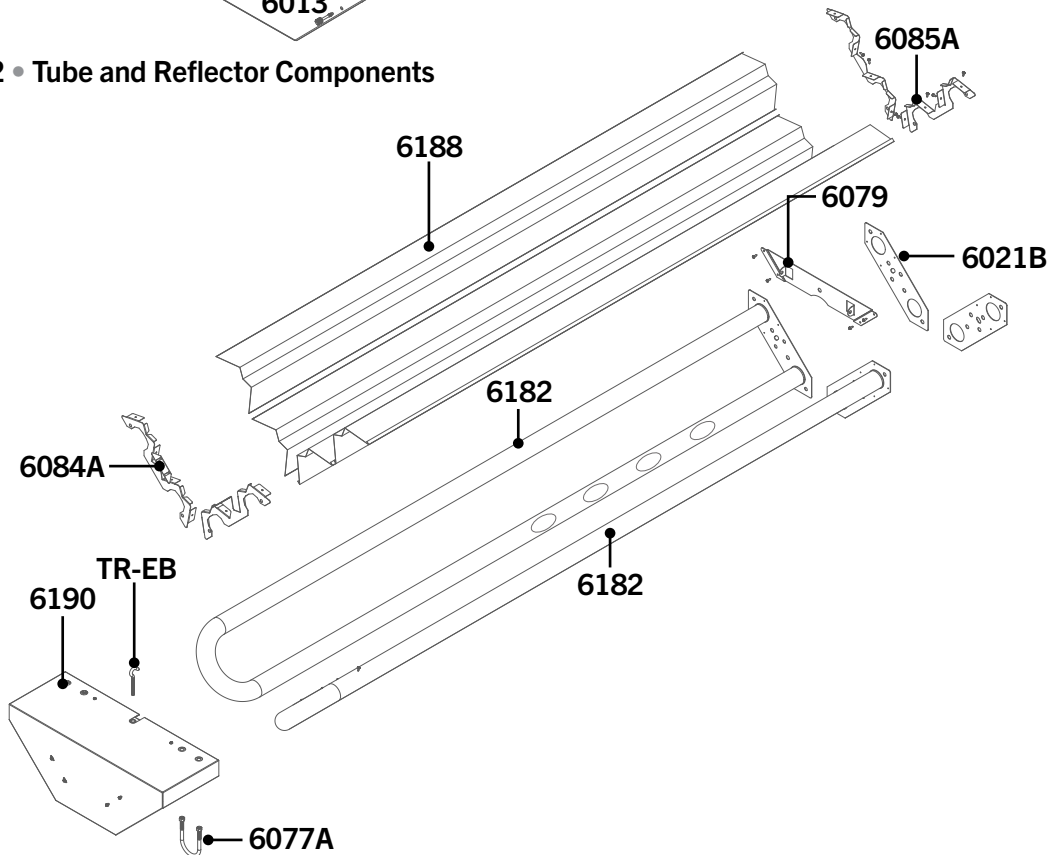

Chart 5.1 • Parts List

Part No.	Description	Part No.	Description
TP-15A	Sight Glass Mica Shield	TP-6106	Burner Box Front Panel
TP-68B	1/2" Strain Relief Bushing	TP-6107	Exhaust Collector Box
TP-826	40 VA Transformer	TP-6108	Service Access Panel
TP-828A	Indicator Light	TP-6115	Inducer Motor
TP-3014	Air Orifice (Specify Size)	TP-6115A	Inducer Motor Insulation
TP-6001	Control Mounting Panel	TP-6115B	Insulation Bracket
TP-6013	Service Access Panel Handle	TP-6116	Inducer Gasket
TP-6021B	Tube Flange Gasket	TP-6119	Burner Mounting Rail
TP-6024	Gas Inlet Adapter	TP-6121	Burner Chamber Cover Panel
TP-6040	Natural Gas Valve	TP-6121A	Burner Chamber Side Panel
TP-6041	Propane Gas Valve	TP-6122	1/2" Snap-In Cord Grip
TP-6044A	Manifold Pipe	TP-6127	1/2" Hole Plug
TP-6044B	Flue Extension	TP-6128	7/8" Hole Plug
TP-6047	5" x 1/2" Gas Inlet Pipe	TP-6130A	Pressure Switch (80,000 BTU)
TP-6048	1/2" Gas Inlet Street Elbow	TP-6130B	Pressure Switch (60,000 BTU)
TP-6051A	Dual DSI Circuit Board	TP-6155	Electrode
TP-6074	Sight Glass	TP-6170	Burner
TP-6075A	Vent Adapter (Not Shown)	TP-6175	Sight Glass Washer
TP-6077A	U-Bolt Fastener	TP-6182	Heat Exchanger Tube
TP-6079	Exchanger and Hanging Bracket	TP-6187	Wire Raceway Clip
TP-6084A	U-End Reflector End Cap	TP-6188	Aluminum Reflector
TP-6085A	Burner Reflector End Cap	TP-6189	Vent Hood (not shown)
TP-6096	1/2" Rubber Grommet	TP-6190	Reflector End Cover Panel
TP-6103	Main Housing Shell	TP-6196	10" x 1/2" Gas Inlet Pipe
TP-6104	Gas Orifice (Specify Size)	TR-EB	3/8"-16 Eyelet Bolt

Routine Inspection

⚠ WARNING



Personal injury or death may result if maintenance is not performed by properly trained gas installer or service personnel. Contact the installing distributor or place of purchase for service. **Do not operate heating system if repairs are necessary.**

Allow heater to cool prior to servicing.

Disconnect power to heater before servicing.

Use protective glasses when servicing the heater.

Never use a pressure washer on any part of the heating system.

Routine Maintenance (After Each Crop)

The heating system should be inspected after each crop to ensure that all heater components are in proper working order and that the heating system operates at peak performance. Particular attention should be paid to the following items:

- **Combustion Air Intake System (when applicable):** Check for blockage and/or leakage. Check the outside termination and the connection at the heater to ensure it is secure.
- **Blower Motor:** Ensure that the squirrel cage of the blower is clean and free from dirt, feathers, and/or other debris. If cleaning is required, an air hose may be used provided care is taken to secure the squirrel cage of the fan first to avoid over-spinning the bearings. If dirt, feathers, and/or other become a problem, installation of outside air intake ducts for combustion is recommended.
- **Reflectors:** To maintain effective infrared heating, always keep both sides of the reflector clean. Dirt and dust can be vacuumed, blown off, or wiped clean with a soap and water solution. Use metal polish if the reflectors are severely dirty. If using a blower to remove debris, use caution so as not to subject the aluminum reflectors to excessive air or pressure which may result in damage.

Inspect the integrity of the reflectors for damage, separation, missing, or misaligned sections, and that reflector rotation does not exceed 45° from horizontal. Ensure that no ceiling material (i.e. tri-ply) is in contact with, or in violation of, the heater's published clearances to combustibles. Do not operate if repairs are necessary. Repair or replace as required per the general installation manual.

- **Heat Exchangers:** Check to ensure there is no soot build up in the exchanger tubes. If soot is present, clean exchanger tubes immediately. **Do not** operate the heater with soot present.

Periodic Maintenance

At least once per year, the heating system should be inspected and serviced by trained gas installation and service personnel only. This inspection should be performed at the beginning of the heating season to ensure that all heater components are in proper working order and that the heating system operates at peak performance. Particular attention should be paid to the following items:

- **Vent Pipe System:** Check the outside termination and the connections at the heater. Inspect the vent exhausts for leakage, damage, fatigue, corrosion, and obstructions. If dirt becomes a problem, installation of outside air intake ducts for combustion is recommended.

Limited Warranty Terms and Conditions

Limited Warranty: Radiant Tube Heaters covered in this manual are warranted by Detroit Radiant Products Company to the original user against defects in workmanship or materials under normal use for one year after date of purchase. Any part which is determined to be defective in workmanship or materials and returned to an authorized service location as Detroit Radiant Products Company designates, shipping costs prepaid, will be, as the exclusive remedy, repaired or replaced at Detroit Radiant Products Company's option. For limited warranty claim procedures, see **Prompt Disposition** below. This limited warranty gives purchasers specific legal rights which vary from jurisdiction to jurisdiction.

Additional Limited Warranty: In addition to the above mentioned one-year warranty, Detroit Radiant Products Company warrants the original purchaser an additional extension on the radiant tubes and combustion burner. This extension excludes electrical/purchased components.

General Conditions: Detroit Radiant Products Company will not be responsible for labor charges for the analysis of a defective condition of the heater or for the installation of replacement parts. The warranties provided herein will not apply if the input of the heater exceeds the rated input at the time of manufacturing or if the heater, in the judgement of Detroit Radiant Products Company, has been subjected to misuse, excessive dust, improper conversion, negligence, accident, corrosive atmospheres, excessive thermal shock, excessive vibration, physical damage to the heater, alterations by unauthorized service personnel, operation contrary to Detroit Radiant Products Company's instructions, or if the serial number has been altered, defaced, or removed. Detroit Radiant Products Company shall not be liable for any default or delay in the performance of these warranties caused by contingency beyond its control including war, government restrictions or restraints, strikes, fire, flood, short or reduced supply of raw materials, or parts.







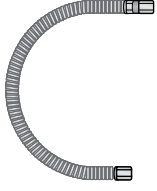
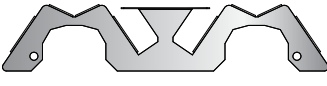
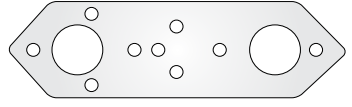

Limitation of Liability: To the extent allowable under applicable law, Detroit Radiant Products Company's liability for consequential and incidental damages is expressly disclaimed. Detroit Radiant Products Company's liability in all events is limited to, and shall not exceed, the purchase price paid.

Warranty Disclaimer: Detroit Radiant Products Company has made a diligent effort to provide product information and illustrate the products in this literature accurately; however, such information and illustrations are for the sole purpose of identification and do not express or imply a warranty that the products are merchantable, fit for a particular purpose, or that the products will necessarily conform to the illustrations or descriptions. Except as provided below, no warranty or affirmation of fact, expressed or implied, other than as stated in the **Limited Warranty** above, is made or authorized by Detroit Radiant Products Company.

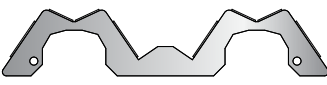
Product Suitability: Many jurisdictions have codes and regulations governing sales, construction, installation, and/or use of products for certain purposes, which may vary from those in neighboring areas. While Detroit Radiant Products Company attempts to assure that its products comply with as many codes as possible, it cannot guarantee compliance and cannot be responsible for how the product is installed or used. Before purchase and use of a product, review the product applications and all applicable national and local codes and regulations to be sure that the product, installation, and use will comply with them. Certain aspects of disclaimers are not applicable to consumer products: e.g., (a) some jurisdictions do not allow the exclusion or limitation of incidental or consequential damages, so the above limitation or exclusion may not apply to you, (b) some jurisdictions do not allow a limitation on how long an implied warranty lasts and, consequently, the above limitation may not apply to you, and (c) by law, during the period of this limited warranty, any implied warranties of implied merchantability or fitness for a particular purpose applicable to consumer products purchased by consumers may not be excluded or otherwise disclaimed.

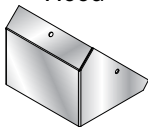
Prompt Disposition: Detroit Radiant Products Company will make a good faith effort for prompt correction or other adjustment with respect to any product which proves to be defective within limited warranty. For any product believed to be defective within limited warranty, first write or call dealer from whom the product was purchased. Dealer will give additional directions. If unable to resolve satisfactorily, write to Detroit Radiant Products Company at the address indicated on page 48 giving the dealer's name, address, date, and number of the dealer's invoice, and describe the nature of the defect. Title and risk of loss pass to the buyer on delivery to common carrier. If product was damaged in transit to you, file a claim with the carrier.

Kit Contents Check List

AVS2 Series Kit Contents			
AK-IP: 29" x 4" PVC Pipe with Attached Intake Cap 	TP-83 24" Stainless Steel Flexible Gas Connector 	TP-6084A: U-End Reflector End Cap 	TP-6021B: Tube Flange Gasket 
AIRH: 18" x 4" Inlet Hose w/ PVC Fitting & Worm Clamp 		TP-6085A: Burner Reflector End Cap 	TP-6022: 5/16" - 18 Keps Nut 
TP-6189: Vent Hood 	THCS: 20" Chain w/ S-Hooks 	TP-33B 1/2" Shut-Off Valve (Ball Valve & 3/8" - 16 Eyelet Inlet Tap) 	TR-EB: 3/8" - 16 Eyelet Bolt 
			LIOAVS2: AVS2 Series Installation Manual 

Box	Part No.	Description	Quantity
T	AIRH	18" x 4" Clear Inlet Hose with PVC Fitting & Worm Clamp	1
T	AK-IP	29" x 4" PVC Pipe with Attached Intake Cap	1
T	AK-WS	2" Wood Screw (Not Pictured)	2
B	LIOAVS2	AVS2 Series Installation Manual	1
T	THCS	Bulldog 12-Ga. 20" Chain with S-Hooks	3
B	TP-13	Self Drilling Screws for Vent Pipe (Not Pictured)	3
B	TP-33B	1/2" Shut-Off Valve (Ball Valve & Inlet Tap)	1
T	TP-62	#8 x 1/2" Screw for Reflectors (Not Pictured)	16
B	TP-83	24" Flexible Connector	1
B	TP-6021B	Tube Flange Gasket	2
B, T	TP-6022	5/16" - 18 Keps Nut	7, 4
T	TP-6084A	U-End Reflector End Cap	2
T	TP-6085A	Burner Reflector End Cap	2
T	TP-6086A	#8 x 1/2" Red Shoulder Screw (Not Pictured)	4
B	TP-6189	Vent Hood	1
B	TR-EB	3/8" - 16 Eyelet Bolt	1

Filled By:

B = Packed with Burner Control Box

T = Packed with Emitter Assembly & Reflectors

Approvals

- CSA
- Indoor/outdoor approval
- Commercial approval

Limited Warranty

- 1 year - Burner box components
- 3 years - Radiant tubes
- 5 years - Combustion burner
- See page 47 for terms and conditions.

