

ELX Series Installation Manual

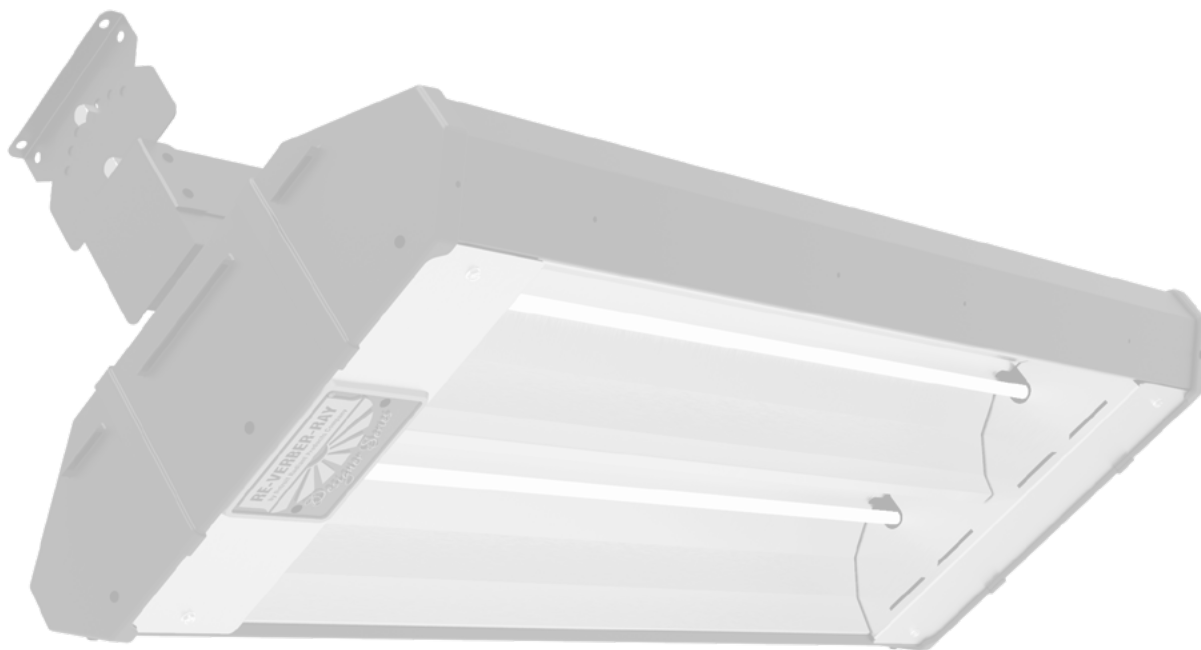

Overhead Electric Infrared Heater with Interchangeable Elements

1, 2, and 3 Lamp Units



⚠ WARNING



All persons involved with the installation, operation, and maintenance of the heater system must read and understand all the information in this manual.

Improper installation, adjustment, alteration, service, or maintenance can cause property damage, injury, or death. Read and understand the installation, operating, and maintenance instructions thoroughly before installing or servicing this equipment.

INSTALLER: Present this manual to the end user.

Keep these instructions in a clean and dry place for future reference.

Model#: _____ Serial #: _____
(located on rating label)

LIOELX-Rev. 17720
Print: 2M-03/22_r3-02/23 (CDS)

Contents

1.0 Safety **3**

 Safety Symbols..... 3

 Applications 3

 Model Number Designation Chart 4

 Available Models and Specifications 4

 Clearances to Combustibles 7

 Safety Labels and Their Locations 9

 Standards, Certifications, and Government Regulations..... 10

2.0 Installation **11**

 Design 11

 Heater Mounting 13

 Lamp Installation 15

 Outdoor Application..... 16

 Electrical Wiring..... 16

3.0 Maintenance **18**

 Troubleshooting Guide 19

 Heater Assembly Components 20

 Parts List 21

4.0 Limited Warranty **24**

⚠ WARNING

California Proposition 65

This product can expose you to chemicals including lead, which is known to the State of California to cause birth defects or other reproductive harm.

For more information, go to www.P65Warnings.ca.gov.

1.0 Safety

⚠ WARNING



Improper installation, adjustment, alteration, service, or maintenance can cause property damage, serious injury, or death. Read and understand the installation, operating, and maintenance instructions thoroughly before installing or servicing this equipment. Only trained, qualified personnel with proper electrical experience may install or service this equipment.

Safety Symbols

Safety is the most important consideration during installation, operation, and maintenance of the infrared heater. You will see the following symbols and signal words when there is a hazard related to safety or property damage.

⚠ WARNING

Warning indicates a potentially hazardous situation which, if not avoided, could result in death or injury.

⚠ CAUTION

Caution indicates a potentially hazardous situation which, if not avoided, could result in minor or moderate injury.

NOTICE

Notice indicates a potentially hazardous situation which, if not avoided, could result in property damage.

Applications

This is not an explosion proof heater. No ELX series heater may be used in a Class 1 or Class 2 Explosive Environment. Consult your local fire marshal, insurance carrier, and other authorities for approval if the proposed installation is in question.

Commercial / Industrial (Indoors & Outdoors)

Infrared heaters are designed and certified for use in industrial and commercial buildings such as warehouses, manufacturing plants, aircraft hangars, and vehicle maintenance shops. For maximum safety, the building must be evaluated for potential hazards before installing the heater system. A critical safety factor to consider before installation is the clearances to combustibles.

Outdoor Residential Only

This heater is **NOT** approved for use in an indoor residential application. This includes, but is not limited to, attached garages, living quarters, solariums, etc. Consult the local fire marshal and/or insurance provider if unsure of your application.

⚠ WARNING



Not For Residential Use.

Installation of this infrared heater system in residential indoor spaces, RVs, mobile homes, etc. may result in property damage, fire, serious injury, or death.

Chart 1.1 • Model Number Designation Chart

Series	Material Type	Lamp Quantity	Voltage	
ELX-24	B = Black Powder Coat with Black Nylon End Caps or	1	120	277
ELX-33		2	208	480
ELX-46	S = Stainless Steel with Black Nylon End Caps	3	240	575

Model Configuration Examples: ELX-24B1-120 or ELX-33S2-277

Chart 1.2 • Available Models and Specifications - 24"

Series	Lamp Type	Voltage*	Total Amps	Total Watts	BTU/h
ELX-24B1-120 / ELX-24S1-120	Short Wave	120 V	12.50	1,500	5,118
	H.O. Medium Wave	120 V	11.30	1,360	4,641
	Medium Wave	120 V	6.25	750	2,559
ELX-24B1-208 / ELX-24S1-208	Short Wave	208 V	7.69	1,600	5,459
	H.O. Medium Wave	208 V	6.53	1,360	4,641
	Medium Wave	208 V	3.60	750	2,559
ELX-24B1-240 / ELX-24S1-240	Short Wave	240 V	6.66	1,600	5,459
	H.O. Medium Wave	240 V	5.66	1,360	4,641
	Medium Wave	240 V	3.12	750	2,559
ELX-24B1-277 / ELX-24S1-277	Short Wave	277 V	5.77	1,600	5,459
	H.O. Medium Wave	277 V	4.90	1,360	4,641
	Medium Wave	277 V	2.70	750	2,559
ELX-24B1-480 / ELX-24S1-480	Short Wave	480 V	3.33	1,600	5,459
	H.O. Medium Wave	480 V	2.83	1,360	4,641
ELX-24B2-120 / ELX-24S2-120	Short Wave	120 V	25.00	3,000	10,236
	H.O. Medium Wave	120 V	22.60	2,720	9,281
	Medium Wave	120 V	12.50	1,500	5,118
ELX-24B2-208 / ELX-24S2-208	Short Wave	208 V	15.38	3,200	10,918
	H.O. Medium Wave	208 V	13.06	2,720	9,281
	Medium Wave	208 V	7.20	1,500	5,118
ELX-24B2-240 / ELX-24S2-240	Short Wave	240 V	13.32	3,200	10,918
	H.O. Medium Wave	240 V	11.32	2,720	9,281
	Medium Wave	240 V	6.24	1,500	5,118
ELX-24B2-277 / ELX-24S2-277	Short Wave	277 V	11.54	3,200	10,918
	H.O. Medium Wave	277 V	9.80	2,720	9,281
	Medium Wave	277 V	5.40	1,500	5,118
ELX-24B2-480 / ELX-24S2-480	Short Wave	480 V	6.66	3,200	10,918
	H.O. Medium Wave	480 V	5.66	2,720	9,281
ELX-24B3-120 / ELX-24S3-120	Medium Wave	120 V	18.75	2,250	7,677
ELX-24B3-208 / ELX-24S3-208	Short Wave	208 V	23.07	4,800	16,378
	H.O. Medium Wave	208 V	19.59	4,080	13,922
	Medium Wave	208 V	10.80	2,250	7,677
ELX-24B3-240 / ELX-24S3-240	Short Wave	240 V	19.98	4,800	16,378
	H.O. Medium Wave	240 V	16.98	4,080	13,922
	Medium Wave	240 V	9.36	2,250	7,677
ELX-24B3-277 / ELX-24S3-277	Short Wave	277 V	17.21	4,800	16,378
	H.O. Medium Wave	277 V	14.70	4,080	13,922
	Medium Wave	277 V	8.10	2,250	7,677
ELX-24B3-480 / ELX-24S3-480	Short Wave	480 V	9.99	4,800	16,378
	H.O. Medium Wave	480 V	8.49	4,080	13,922

Chart 1.3 • Available Models and Specifications - 33"

Series	Lamp Type	Voltage*	Total Amps	Total Watts	BTU/h
ELX-33B1-120 / ELX-33S1-120	Medium Wave	120 V	10.41	1,250	4,265
ELX-33B1-208 / ELX-33S1-208	Short Wave	208 V	12.00	2,500	8,530
	H.O. Medium Wave	208 V	10.20	2,125	7,251
	Medium Wave	208 V	6.00	1,250	4,265
ELX-33B1-240 / ELX-33S1-240	Short Wave	240 V	10.41	2,500	8,530
	H.O. Medium Wave	240 V	8.85	2,125	7,251
	Medium Wave	240 V	5.20	1,250	4,265
ELX-33B1-277 / ELX-33S1-277	Short Wave	277 V	9.02	2,500	8,530
	H.O. Medium Wave	277 V	7.67	2,125	7,251
	Medium Wave	277 V	4.51	1,250	4,265
ELX-33B1-480 / ELX-33S1-480	Short Wave	480 V	5.20	2,500	8,530
	H.O. Medium Wave	480 V	4.42	2,125	7,251
ELX-33B2-120 / ELX-33S2-120	Medium Wave	120 V	20.82	2,500	8,530
ELX-33B2-208 / ELX-33S2-208	Short Wave	208 V	24.00	5,000	17,061
	H.O. Medium Wave	208 V	20.40	4,250	14,502
	Medium Wave	208 V	12.00	2,500	8,530
ELX-33B2-240 / ELX-33S2-240	Short Wave	240 V	20.82	5,000	17,061
	H.O. Medium Wave	240 V	17.70	4,250	14,502
	Medium Wave	240 V	10.40	2,500	8,530
ELX-33B2-277 / ELX-33S2-277	Short Wave	277 V	18.04	5,000	17,061
	H.O. Medium Wave	277 V	15.34	4,250	14,502
	Medium Wave	277 V	9.02	2,500	8,530
ELX-33B2-480 / ELX-33S2-480	Short Wave	480 V	10.40	5,000	17,061
	H.O. Medium Wave	480 V	8.84	4,250	14,502
ELX-33B3-208 / ELX-33S3-208	Medium Wave	208 V	18.00	3,750	12,796
ELX-33B3-240 / ELX-33S3-240	Medium Wave	240 V	15.60	3,750	12,796
ELX-33B3-277 / ELX-33S3-277	Short Wave	277 V	27.06	7,500	25,591
	H.O. Medium Wave	277 V	23.01	6,375	21,752
	Medium Wave	277 V	13.53	3,750	12,796
ELX-33B3-480 / ELX-33S3-480	Short Wave	480 V	15.60	7,500	25,591
	H.O. Medium Wave	480 V	13.26	6,375	21,752

* Heaters are configured at the factory for single phase wiring. If three phase service is desired, it must be wired as such in the field by a trained installer / electrical contractor.

Chart 1.4 • Available Models and Specifications - 46"

Series	Lamp Type	Voltage*	Total Amps	Total Watts	BTU/h
ELX-46B1-208 / ELX-46S1-208	Medium Wave	208 V	9.61	2,000	6,824
ELX-46B1-240 / ELX-46S1-240	Medium Wave	240 V	8.33	2,000	6,824
ELX-46B1-277 / ELX-46S1-277	Short Wave	277 V	11.55	3,200	10,919
	H.O. Medium Wave	277 V	11.55	3,200	10,919
	Medium Wave	277 V	7.22	2,000	6,824
ELX-46B1-480 / ELX-46S1-480	Short Wave	480 V	7.60	3,650	12,454
	H.O. Medium Wave	480 V	6.66	3,200	10,919
	Medium Wave	480 V	4.16	2,000	6,824
ELX-46B1-575 / ELX-46S1-575	Short Wave	575 V	6.60	3,800	12,966
	H.O. Medium Wave	575 V	5.56	3,200	10,919
	Medium Wave	575 V	5.21	3,000	10,236
ELX-46B2-208 / ELX-46S2-208	Medium Wave	208 V	19.22	4,000	13,649
ELX-46B2-240 / ELX-46S2-240	Medium Wave	240 V	16.66	4,000	13,649
ELX-46B2-277 / ELX-46S2-277	Short Wave	277 V	23.10	6,400	21,838
	H.O. Medium Wave	277 V	23.10	6,400	21,838
	Medium Wave	277 V	14.44	4,000	13,649
ELX-46B2-480 / ELX-46S2-480	Short Wave	480 V	15.20	7,300	24,909
	H.O. Medium Wave	480 V	13.32	6,400	21,838
	Medium Wave	480 V	8.32	4,000	13,649
ELX-46B2-575 / ELX-46S2-575	Short Wave	575 V	13.20	7,600	25,932
	H.O. Medium Wave	575 V	11.12	6,400	21,838
	Medium Wave	575 V	10.42	6,000	20,473
ELX-46B3-208 / ELX-46S3-208	Medium Wave	208 V	28.83	6,000	20,473
ELX-46B3-240 / ELX-46S3-240	Medium Wave	240 V	24.99	6,000	20,473
ELX-46B3-277 / ELX-46S3-277	Medium Wave	277 V	21.66	6,000	20,473
ELX-46B3-480 / ELX-46S3-480	Short Wave	480 V	22.80	10,950	37,363
	H.O. Medium Wave	480 V	19.98	9,600	32,757
	Medium Wave	480 V	12.48	6,000	20,473
ELX-46B3-575 / ELX-46S3-575	Short Wave	575 V	19.80	11,400	38,898
	H.O. Medium Wave	575 V	16.68	9,600	32,757
	Medium Wave	575 V	15.63	9,000	30,709

* Heaters are configured at the factory for single phase wiring. If three phase service is desired, it must be wired as such in the field by a trained installer / electrical contractor.

Clearances to Combustibles

⚠ WARNING



Placement of explosive objects, flammable objects, liquids, and vapors close to the heater may result in explosion, fire, property damage, serious injury, or death. Do not store or use explosive objects, liquids, or vapors in the vicinity of the heater.

Failure to comply with the published clearances to combustibles could result in personal injury, death, and/or property damage.

The outside surfaces of the heater are hot during operation and after operation. If contact is made, permanent skin damage may occur. Do not move, handle, or service the unit during operation or while hot.

⚠ CAUTION



Signs shall be posted specifying the maximum permissible stacking height in order to maintain clearances to combustibles.

Hazards Include:

For maximum safety the building must be evaluated for hazards before installing the heater system. Examples include, but are not limited to:

- Gas and electrical lines
- Combustible and explosive materials
- Chemical storage areas
- Areas of high chemical fume concentrations
- Provisions for accessibility to the heater
- Adequate clearances around air openings
- Vehicle parking areas
- Vehicles with lifts or cranes
- Storage areas with stacked materials
- Lights
- Sprinkler heads
- Overhead doors and tracks
- Dirty, contaminated environment

A critical safety factor to consider before installation is the clearances to combustibles. **Clearance to combustibles** is defined as *the minimum distance you must have between the indicated surface and the combustible item*. Considerations must also be made for moving objects around the infrared heater. The following is a partial list of items to maintain clearances from:

Combustible Items Include:

- Wood
- Paper
- Fabric
- Chemicals
- Wall or roof insulation
- Plastics

Moving Objects Include:

- Overhead doors
- Vehicles on lifts
- Cranes
- Hoists

When installing the infrared heater system, the minimum clearances to combustibles must be maintained. These distances are shown in Chart 1.5 and on the heater. If you are unsure of the potential hazards, consult your local fire marshal, fire insurance carrier, or other qualified authorities on the installation of infrared heaters for approval of the proposed installation.

Chart 1.5 • Clearances to Combustibles in Inches (Millimeters) - see Figure 1.1

Length	Mounting Angle	Side		End	Top	Below	Min. Mtg. Height	
		Front	Behind				US	Canada
Single Element								
24" 33" 46"	0°	16 (407)	16 (407)	12 (305)	6 (153)	56 (1423)	6 ft.	2.4 m
	45°	47 (1194)	4 (102)	12 (305)	10 (254)	40 (1016)		
Double Element								
24" 33" 46"	0°	28 (712)	28 (712)	26 (661)	6 (153)	86 (2185)	7.5 ft.	2.4 m
	45°	86 (2185)	4 (102)	26 (661)	10 (254)	86 (2185)		
Triple Element								
24" 33" 46"	0°	31 (788)	31 (788)	34 (864)	9 (229)	105 (2667)	9 ft.	2.8 m
	45°	105 (2667)	4 (102)	34 (864)	10 (254)	105 (2667)		

* Heaters mounted on an angle between 0° and 45° must maintain clearances posted for 0° or 45°, whichever is greater.

** Clearances to combustibles must be maintained when using recessed mount kits (P/N: ELx-FRxx). For additional information, refer to form # LSH123a - Recessed Mounting Frame Installation Instructions or contact the factory.

NOTE: Ensure that building materials with a low heat tolerance (i.e, awnings, fabrics, plastics, sprinklers, insulation, etc.) are protected against degradation. This may require the heater to be mounted at a distance in excess of the published clearances to combustibles. Contact the material manufacturer for specific details.

Figure 1.1 • Clearances to Combustibles

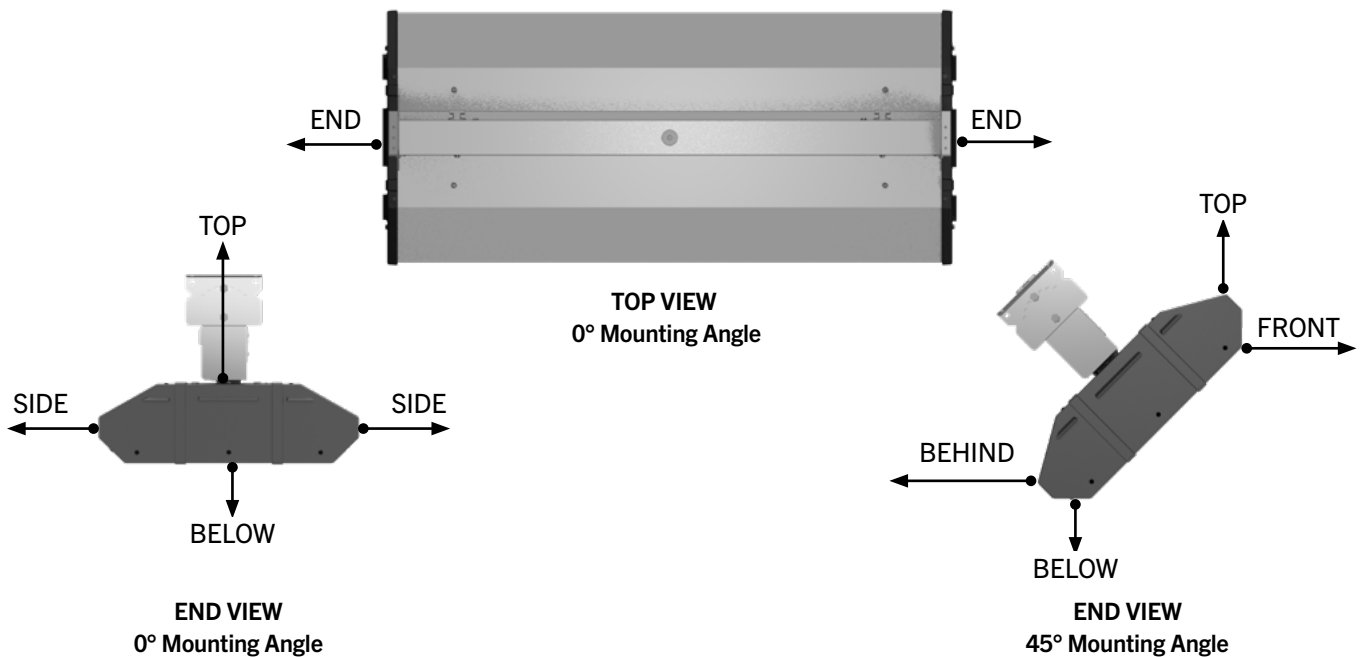

Safety Labels and Their Locations

It is important to provide warnings to alert individuals to potential hazards and safety actions. Signs should state the hazards for the particular application and be legible to the building occupants. Consult the factory or a factory representative for additional information on signage compliance.

Safety warning labels must be maintained on the infrared heater. Illustrations of the safety labels and their locations are pictured below. When no longer legible, they must be replaced. Contact either your local distributor or the product manufacturer for obtaining replacement signs or labels.

Top View

F/N: LLECL001a - Clearances to Combustibles Label

Length	Mounting Angle	Front		Side		End	Top	Below
		Behind	End	Behind	End			
ELX Series Single Element								
24"	0°	16 (407)	16 (407)	12 (305)	6 (153)	56 (1423)		
33"	45°	47 (1194)	4 (102)	12 (305)	10 (254)	40 (1016)		
ELX Series Double Element								
24"	0°	28 (712)	28 (712)	26 (661)	6 (153)	86 (2185)		
33"	45°	86 (2185)	4 (102)	26 (661)	10 (254)	86 (2185)		
ELX Series Triple Element								
24"	0°	31 (788)	31 (788)	34 (864)	9 (229)	105 (2667)		
33"	45°	105 (2667)	4 (102)	34 (864)	10 (254)	105 (2667)		

Heaters mounted on an angle between 0° and 45° must maintain clearances posted for 0° or 45°, whichever is greater.

F/N: LL001 - Clearance Safety Tag
(Affix adjacent to heater's controller)

WARNING
Avoid Serious Injury, Death, or Property Damage. Maintain Clearances to Combustible to Prevent the Risk of Fire.
Clearances to combustibles must be maintained at all times in order to prevent the ignition of combustible materials. In locations used for the storage of combustible materials, signs must be posted to specify the maximum permissible stacking height to maintain the required clearances from the heater to the combustibles. Signs must either be posted adjacent to the heater's thermostats or, in the absence of such thermostats, in a conspicuous location. Clearances are provided on the heater's safety label and in the heater's Installation, Operation, and Maintenance manual. Product installation and operation must comply with applicable standards, codes, and regulations. Post this tag adjacent to the heater's thermostat or controls before operating the heater.

California Proposition 65
This product can expose you to chemicals including lead and carbon monoxide, which are known to the State of California to cause birth defects or other reproductive harm.
For more information go to www.P65Warnings.ca.gov.

Rating Plate

ELECTRIC INFRARED HEATER		INFRAROUGE A CHAUFFE AU ELECTRIQUE	
MODEL NUMBER / NUMÉRO DE MODÈLE	ELX-24B1-120	SERIAL NUMBER / NUMÉRO DE SÉRIE	2002DETRXXXXXX0001
VOLTAGE / TENSION	120	RATING RANGE / PLAGE DE PUISSANCE	750-1600
PHASE	Single	VERSION	01/20
MIN. MOUNTING HEIGHT / HAUTEUR MINIMALE DE MONTAGE	6 ft. / 1.8 m	MIN. MOUNTING ANGLE / MIN. ANGLE DE SUPPORT	0°
MAX. MOUNTING ANGLE / MAX. ANGLE DE SUPPORT	45°	FREQUENCY / FRÉQUENCE	50/60 Hz
THIS HEATER COMPLIES WITH STANDARDS / COMPLEX DE CETTE CONCEPTION AVEC LA NORME: UL 2021 - Edition 6 (revision 2018) • CSA C22.2 46-13 (R2018)			
THIS HEATER WAS INSTALLED WITH THE FOLLOWING ELEMENTS / CET APPAREIL DE CHAUFFAGE A ÉTÉ INSTALLÉ AVEC LES ÉLÉMENTS SUIVANTS:		Element Part Number:	EL-MV-A2H EL-HO-A2H EL-SC-A2H EL-SR-A2H
Output Wave:	Medium	H.O. Medium	Short - Clear Short - Ruby
Amperes per Lamp / Total Amps:	6.25 / 6.25	11.30 / 11.30	12.50 / 12.50 12.00 / 12.50
Watts per Lamp / Total Watts:	750 / 750	1360 / 1360	1500 / 1500 1500 / 1500
Detroit Radiant Products Company 21400 Hoover Road, Warren, MI 48099 (586) 789-9955 www.reverberary.com		FOR COMMERCIAL, INDUSTRIAL, AND OUTDOOR RESIDENTIAL USE. FOR INDOOR OR OUTDOOR USE. MADE IN USA.	

Standards, Certifications, and Government Regulations

Installation of this infrared heater must comply with all applicable local, state, and national specifications, regulations, and building codes. Contact the local building inspector and/or fire marshal for guidance.

The heater must be electrically grounded in accordance with the following codes:

United States: Refer to National Electrical Code®, ANSI/NFPA 70 (latest edition).
Wiring must conform to the latest edition of National Electrical Code®, local ordinances, and any special diagrams from the manufacturer.

Canada: Refer to Canadian Electrical Code CSA C22.1 Part 1 (latest edition).

Detroit Radiant Products Company units comply with or are certified by one or more of the following organizations or standards:

- CSA 22.2 #46 - M1988
- UL 2021

2.0 Installation

⚠ WARNING



Read and understand the installation, operation, and maintenance instructions thoroughly before installing or servicing this equipment.

Design

To ensure a safe, properly designed heating system, a layout should be developed for the correct placement of the infrared heater(s).

Aside from safety factors such as clearances to combustibles (see Chart 1.5 on page 8), consideration should also be given to factors such as the environment (e.g., cold/drafty, average, protected), heat coverage (sq. ft.) needed, heater centers, the distance behind a person or work station(s), etc. Also, the effective infrared surface temperature of a person or object may be diminished with wind above 5 mph. Wind barrier(s) may be required. Most importantly, clearances to combustibles **must** always be maintained! Refer to hazards on page 7.

When positioning the heaters, keep in mind the location of combustible materials, lights, sprinkler heads, overhead doors, storage areas with stacked materials, gas and electrical lines, parked vehicles, cranes, etc. Refer to page 6 for minimum clearances to verify that a safe installation exists.

This installation manual, along with national, state, provincial, and local codes, addresses these issues. It is critical that you read, understand, and follow all guidelines and instructions. Always inspect and evaluate the mounting conditions, application, and wiring.

When heated, materials high in hydrocarbons (solvents, paint thinner, mineral spirits, formaldehydes, etc.) can evaporate and/or degrade. This may result in odors or fumes being emitted into the environment. To correct this problem, clean the area and/or introduce additional ventilation. Heaters installed and serviced in accordance with the installation manual do not emit foul odors into the environment.

IMPORTANT: Fire sprinkler heads must be located at an appropriate distance from the heater to avoid an inadvertent discharge. This distance may exceed the published clearances to combustibles. Certain applications may require the use of high temperature sprinkler heads or relocation of the heaters.

⚠ CAUTION

Fire sprinkler systems containing propylene glycol, antifreeze, or other potentially flammable substances shall not be used in conjunction with this heater without careful consideration for, and avoidance of, inadvertent discharge hazards. For further information consult applicable NFPA codes. Always observe applicable state and local codes.

Chart 2.1 • Estimating Required Heat Load

Type of Building	Watts Required per Square Foot at Floor Level*
Insulated	5 to 10
Uninsulated	10 to 15
Outdoor Sheltered	20 to 30
Outdoor Unsheltered	25 to 40

* For load purposes only, not for determining coverage.

When comfort heating people, two heaters should be used to heat both sides of the individual. Heater installation shall comply with all IOPM, NEC, ANSI/NFPA-70, CEC, and local restrictions.

Chart 2.2 • Heating Application Chart

Series	Lamp Quantity	Minimum Mounting Height (Ft.)		Recommended Mounting Height (Ft.)** [Dim. A]	Recommended Distance Between Heaters (Ft.) [Dim. B]	Approximate† Square Foot Coverage
		US	Canada			
ELX-24	1	6 ft.	2.4 m	10 to 12	5 to 10	100 to 200
	2	7.5 ft.	2.4 m	10 to 12	6 to 12	150 to 250
	3	9 ft.	2.8 m	12 to 14	7 to 14	200 to 300
ELX-33	1	6 ft.	2.4 m	10 to 12	6 to 12	200 to 300
	2	7.5 ft.	2.4 m	12 to 14	7 to 14	250 to 350
	3	9 ft.	2.8 m	12 to 14	8 to 16	300 to 400
ELX-46	1	6 ft.	2.4 m	12 to 14	7 to 14	300 to 400
	2	7.5 ft.	2.4 m	14 to 16	8 to 16	350 to 450
	3	9 ft.	2.8 m	14 to 16	9 to 18	400 to 500

** Clearances to combustibles published in this manual and on safety labels must be maintained at all times. Factory recommended mounting heights are listed as a guideline. If infrared heaters are mounted too low or too high, they may result in discomfort or lack of heat.

† Approximation only. Mounting height and environmental conditions will impact performance.

Figure 2.1 • Heating Application

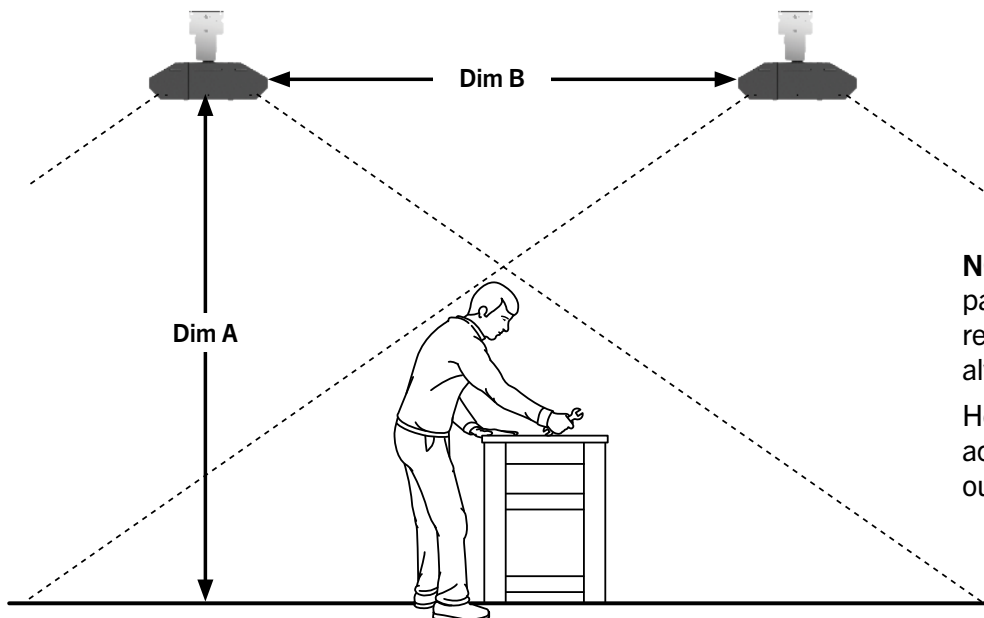

NOTE: Typical height above patrons is 2 to 6 ft. (minimum required mounting height must always be maintained).

Heat loads estimated are to achieve a perceived 10° to 15°F outdoor temperature rise.

Heater Mounting

⚠ WARNING



Improper suspension of the infrared heater may result in collapse and being crushed. Always suspend from a permanent part of the building structure that can support the total force and weight of the heater.



Failure to maintain minimum clearance to combustibles may result in fire and/or explosion, property damage, serious injury, or death. Always maintain minimum clearances and post signs or provided tags (F/N: LL001) adjacent to heater's controller. Signs should state the hazards for the particular application and be legible to the building occupants. Consult the factory or a factory representative for additional information on signage compliance.

The heater can be suspended with chains or rigid threaded rod. Local codes, or conditions that would cause the unit to move (e.g., wind drafts, blowers, crane rails, etc.), may require rigid threaded rod. Consult all applicable codes before installation.

Clearances to combustibles must be maintained when using recessed mount kits (P/N: ELx-FRxx). For additional information, refer to form # LSH123a - Recessed Mounting Frame Installation Instructions or contact the factory.

The heater must be level from end to end and may be 0° to 45° on horizontal. Refer to Figures 2.2 and 2.3.

Figure 2.2 • Heater Dimensions

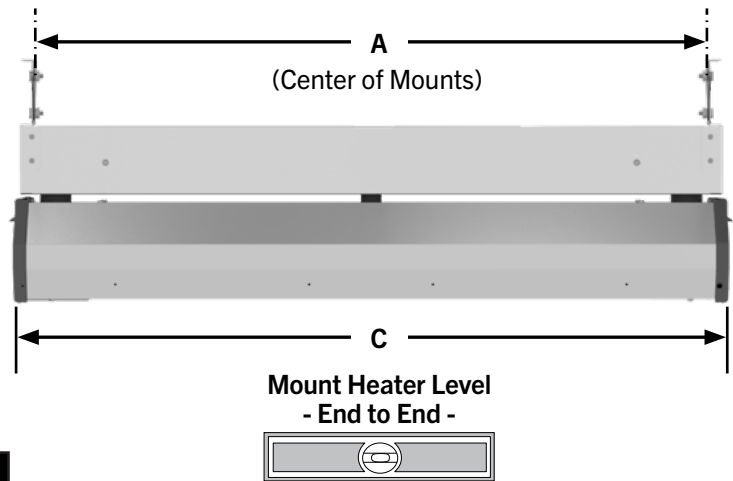
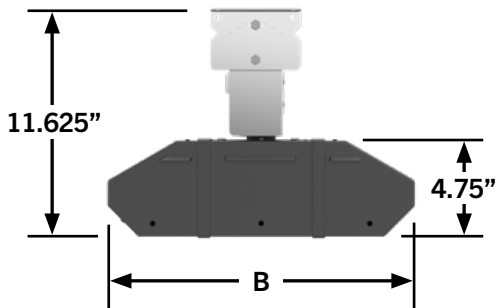
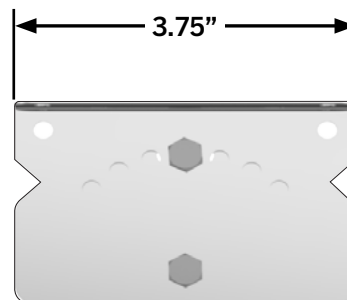

Chart 2.3 • Physical Dimensions (inches)

Model No.	A	B	C
ELX-24X1	23.50	9.625	24.50
ELX-24X2	23.50	15.25	24.50
ELX-24X3	23.50	21.00	24.50
ELX-33X1	32.50	9.625	33.50
ELX-33X2	32.50	15.25	33.50
ELX-33X3	32.50	21.00	33.50
ELX-46X1	45.50	9.625	46.50
ELX-46X2	45.50	15.25	46.50
ELX-46X3	45.50	21.00	46.50

Figure 2.3 • Mounting Centers



Top Channel Assembly

- 1 Attach the mounting brackets to the top wire raceway. On each end, place (1) $\frac{1}{4}$ " x $\frac{1}{2}$ " bolt through the bottom hole of the mounting bracket and through the bottom hole of the top wire raceway. Place (1) $\frac{1}{4}$ " lock nut on each bolt. Do not tighten completely. Refer to Figure 2.4.

NOTE: The mounting brackets are **NOT** required for chain suspension.

- 2 Adjust wire raceway to desired mounting angle.
- 3 On each side, place (1) $\frac{1}{4}$ " x $\frac{1}{2}$ " bolt through slot in the mounting bracket and the hole in the top wire raceway. Place (1) $\frac{1}{4}$ " lock nut on each bolt and tighten.
- 4 Tighten lock nuts from Step 1.
- 5 Hook heater body into mounted wire raceway. Unit will hang freely by the "T" hinge, leaving both hands free to wire unit. Refer to Figure 2.4.
- 6 Run supplied high temperature wires out to field supplied junction box. **DO NOT** make connections inside the wire raceway.
- 7 Close wire raceway using the (4) #8-32 x $\frac{3}{8}$ " grounding screws provided in hardware pack.

Figure 2.4 • Top Channel Assembly

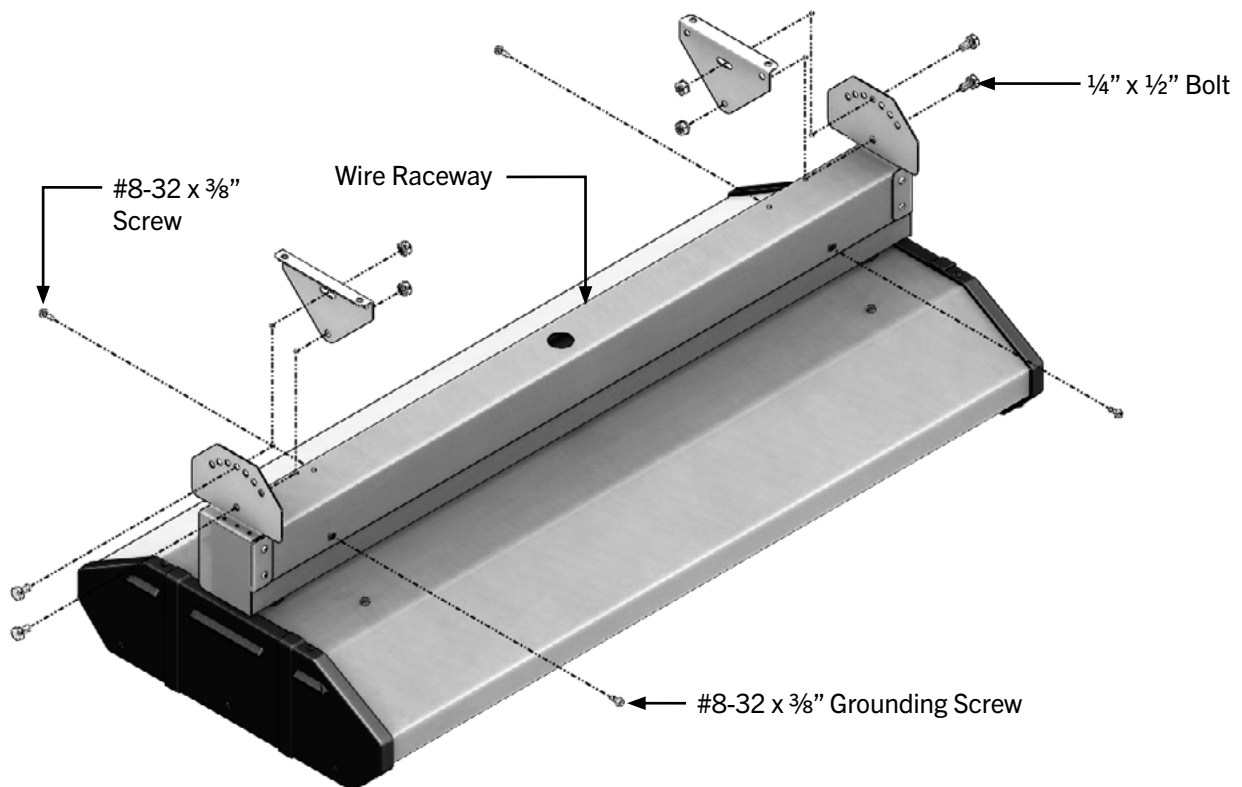

Lamp Installation

⚠ CAUTION

Disconnect power prior to installing or replacing supplied quartz lamp(s). The elements can and should be installed prior to mounting the heater.

- ① Ensure appliance is OFF and is cool to the touch.
- ② Remove both service access panels using a ¼" nut driver.
- ③ Open lamp retainers by rotating the retainers on both sides of the unit (see Figure 2.5).
- ④ Position heating elements in "U" slots and firmly press the ceramic connector end into the clip(s), one end at a time. Avoid handling the quartz glass as much as possible.
- ⑤ Remove the top element wire retaining nut. Slide the ring terminal over the bolt until it meets the bottom retaining nut. Replace top retaining nut and torque to 15 in.-lbs. Do not overtighten.
- ⑥ Rotate the lamp retainer into closed position.
- ⑦ Repeat steps 3 through 6 until all heating elements have been installed.
- ⑧ After heating elements have been installed, the quartz glass should be wiped down with alcohol using a clean cloth.
- ⑨ Reinstall the service access panels.

Figure 2.5 • Lamp Installation

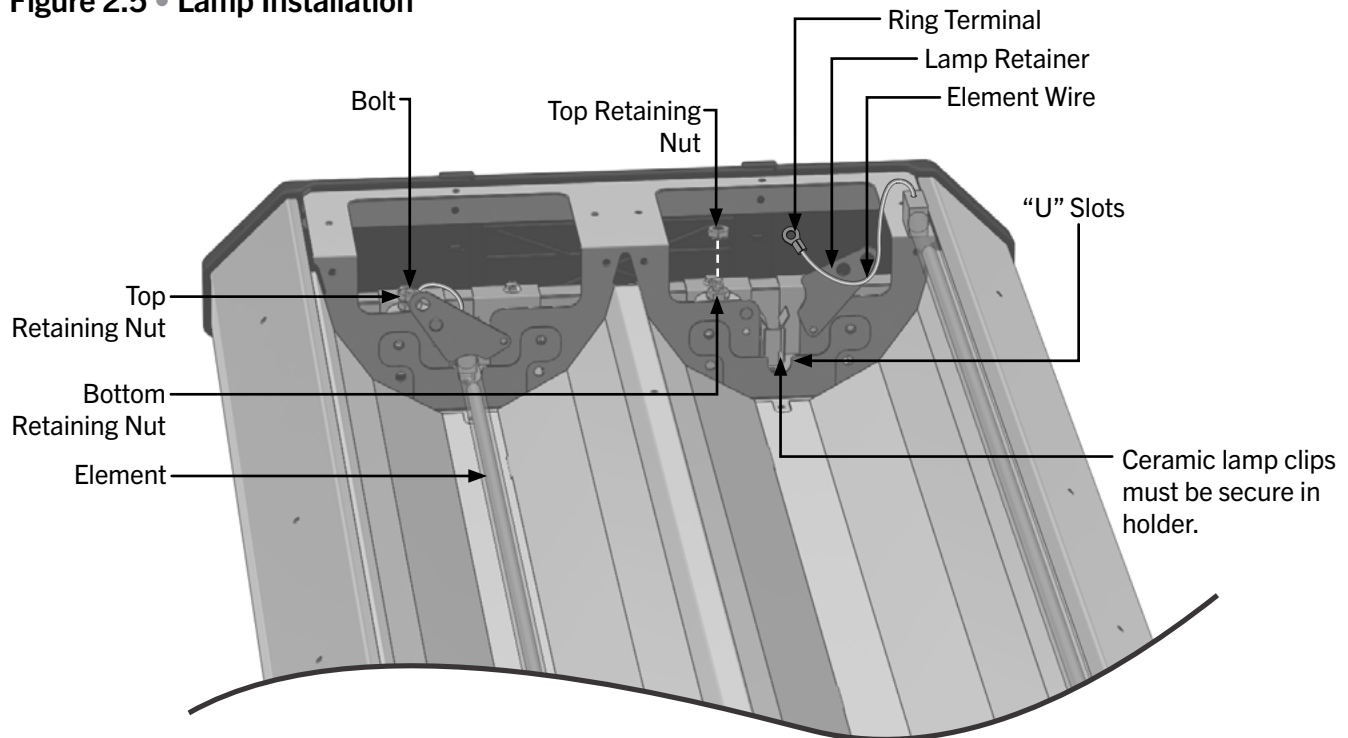

NOTE: ELX series heaters are designed for use with quartz lamp infrared heating elements only. They are NOT intended to be used with straight metal rod heating elements. Replace lamps with parts from Detroit Radiant Products Company only!

Outdoor Applications

⚠ CAUTION

For totally exposed outdoor applications (not ceiling protected) ensure connections are made as illustrated in Figure 2.6.

Figure 2.6 • Outdoor Application

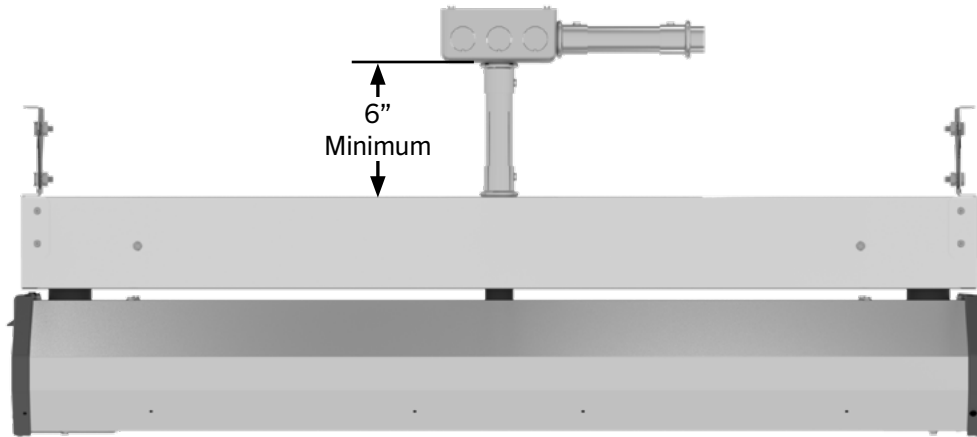

NOTE: All conduit, conduit fittings, and junction boxes are field supplied. Must be NEMA Type 4X or equivalent. Heater must be suspended from mounting brackets.

Electrical

⚠ WARNING



Electric Shock

Field wiring to the heater must be connected and grounded in accordance with national, state, provincial, and local codes, and to the guidelines in this manual. In the United States, refer to the most current revisions to the ANSI/NFPA 70 Standard and in Canada, refer to the most current revisions to the CSA C22.1 Part I Standard.

Disconnect power to heater before servicing.

Failure to follow these instructions can result in death or electrical shock.

This fixture is equipped with high temperature silicone lead wires to make connections to branch circuit. Remove the wire ties prior to making electrical connections.

Wiring connections should always be through one of the knockouts in the top wire raceway. Wire connections must also be made outside of the top of the wire raceway. Consult the factory or a qualified electrician for details on staging.

Supply wires must be a copper conductor type with a minimum size of 10 AWG suitable for at least 200°C.

The heater must be connected to the earthing conductor (green wire) installed by the factory.

Reference top of page 16 for use in outdoor applications.

Wiring Diagrams

Figure 2.7 • Wiring Diagram for Units with 1 Lamp



Figure 2.8 • Wiring Diagram for Units with 2 Lamps

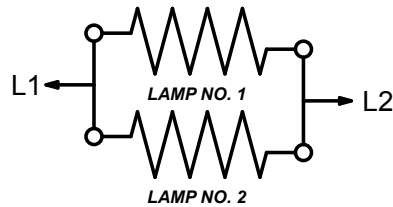
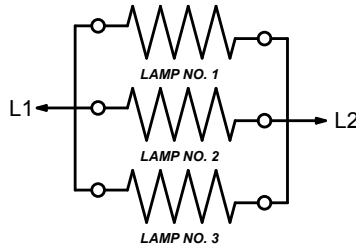

Figure 2.9 • Wiring Diagram for Units with 3 Lamps



Field Wiring

Figure 2.10 • Single Phase Service
Heaters are built as single phase.

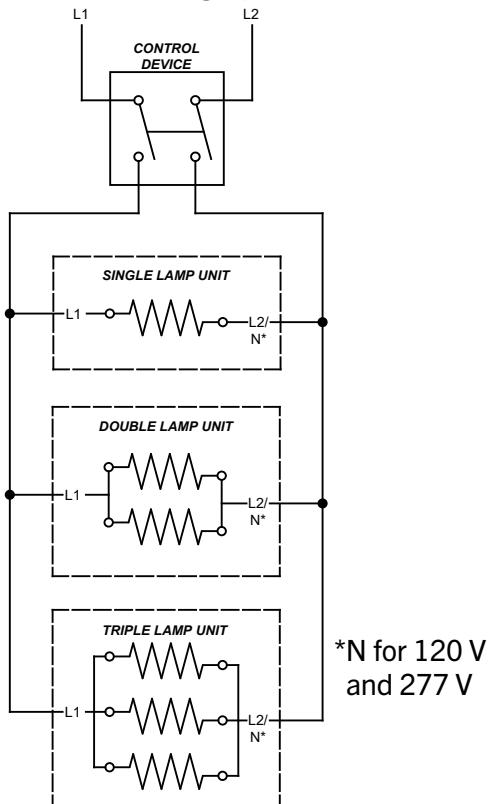
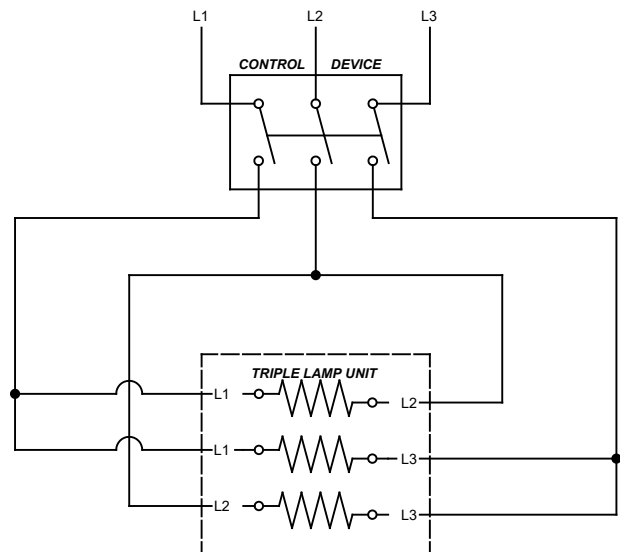
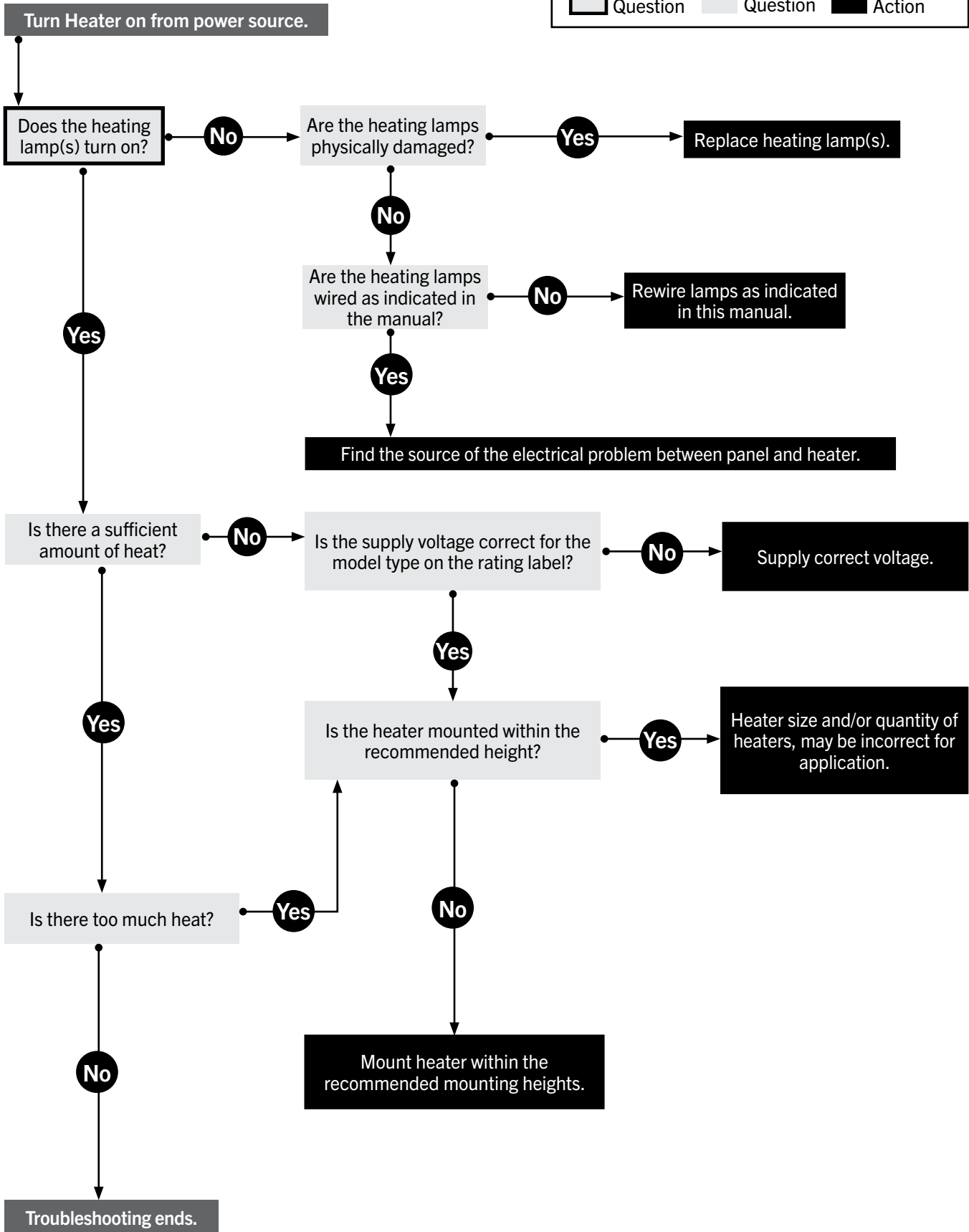

Figure 2.11 • Three Phase Service
Field configured.



Troubleshooting Guide

Key					
	Start Question		Process Question		Corrective Action



Heater Assembly Components

For complete information on ELX series replacement parts, visit the online replacement parts library at www.reverberray.com/shop. For discontinued models, consult the factory.

Figure 3.1 • Components

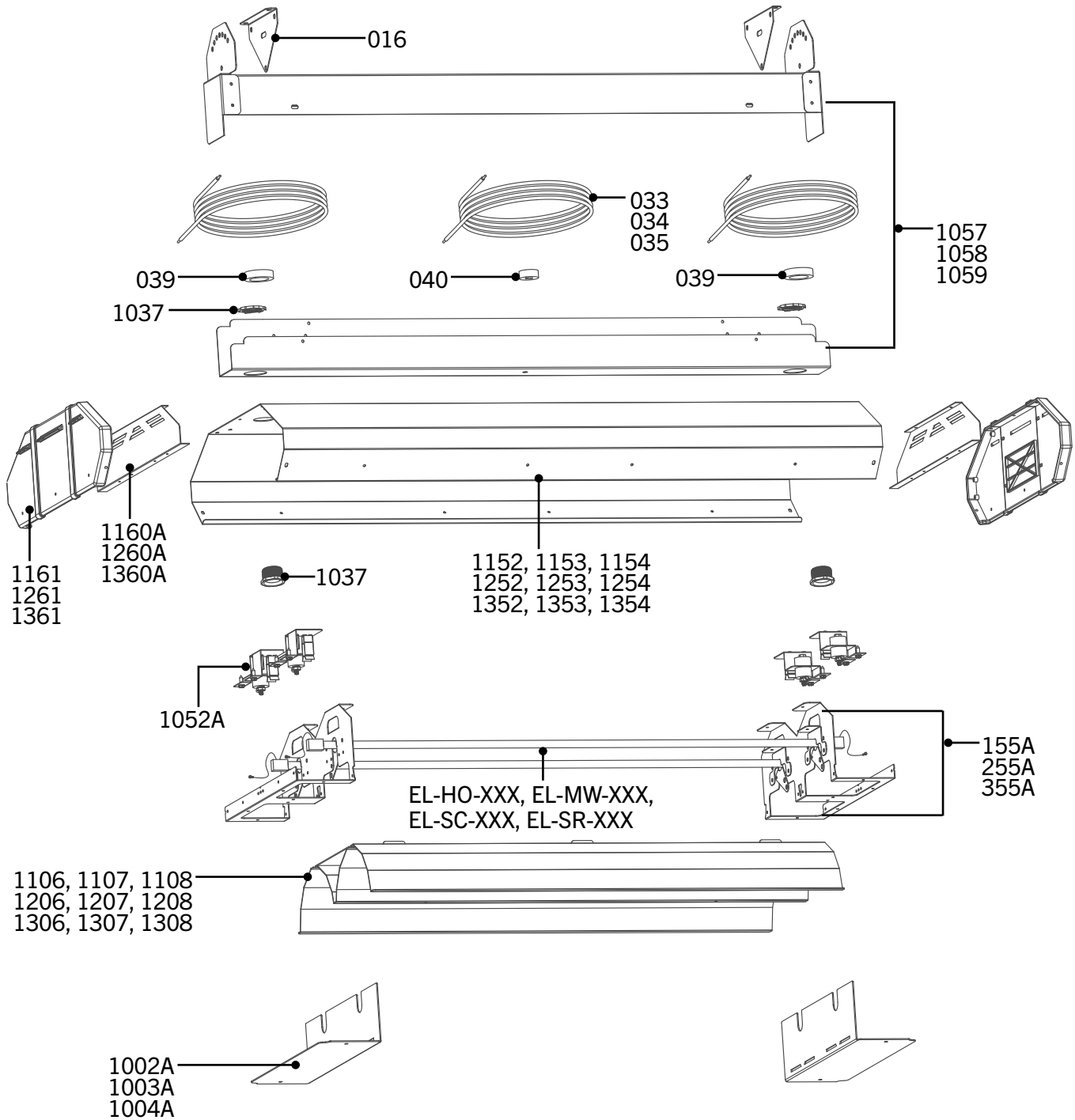

Parts List

Chart 3.1 • General Parts

Part No.	Description	Part No.	Description
EL-016 ¹	Mounting Brackets (set of 2)	Double Element Model-Specific Parts	
EL-033	12 Gauge Wire Length for 33" (specify color)	EL-255A	Chassis Assembly with Lamp Stopper
EL-034	12 Gauge Wire Length for 24" (specify color)	EL-1003A	Service Access Panel - Vented
EL-035	12 Gauge Wire Length for 46" (specify color)	EL-1206	Reflector, 24" Model
EL-039	Large Rubber Spacer (End - 2 per heater)	EL-1207	Reflector, 33" Model
EL-040	Small Rubber Spacer (Center)	EL-1208	Reflector, 46" Model
EL-1037	Wire Bushing	EL-1252 ¹	Shell Assembly, 24" Model
EL-1052A	Element Connector Assembly	EL-1253 ¹	Shell Assembly, 33" Model
EL-1057 ¹	Wire Raceway Assembly, 24" Model	EL-1254 ¹	Shell Assembly, 46" Model
EL-1058 ¹	Wire Raceway Assembly, 33" Model	EL-1260A	Rain Shield - Vented
EL-1059 ¹	Wire Raceway Assembly, 46" Model	EL-1261	Nylon End Panel
Single Element Model-Specific Parts		Triple Element Model-Specific Parts	
EL-155A	Chassis Assembly with Lamp Stopper	EL-355A	Chassis Assembly with Lamp Stopper
EL-1002A	Service Access Panel - Vented	EL-1004A	Service Access Panel - Vented
EL-1106	Reflector, 24" Model	EL-1306	Reflector, 24" Model
EL-1107	Reflector, 33" Model	EL-1307	Reflector, 33" Model
EL-1108	Reflector, 46" Model	EL-1308	Reflector, 46" Model
EL-1152 ¹	Shell Assembly, 24" Model	EL-1352 ¹	Shell Assembly, 24" Model
EL-1153 ¹	Shell Assembly, 33" Model	EL-1353 ¹	Shell Assembly, 33" Model
EL-1154 ¹	Shell Assembly, 46" Model	EL-1354 ¹	Shell Assembly, 46" Model
EL-1160A	Rain Shield - Vented	EL-1360A	Rain Shield - Vented
EL-1161	Nylon End Panel	EL-1361	Nylon End Panel

¹ Order part number as is for black finish or add -SS for stainless steel finish. Ex: EL-016 for black mounting brackets and EL-016-SS for stainless steel mounting brackets.

Visit our online parts reference library at www.reverberray.com/shop for further technical data related to parts.

Chart 3.2 • Elements

Part No.	Description	Part No.	Description
Short Wave - Clear		High-Output Medium Wave	
EL-SC-A24	120 V, 1500 W, 24" Long	EL-HO-A24	120 V, 1360 W, 24" Long
EL-SC-B24	208 V, 1600 W, 24" Long	EL-HO-B24	208 V, 1360 W, 24" Long
EL-SC-C24	240 V, 1600 W, 24" Long	EL-HO-C24	240 V, 1360 W, 24" Long
EL-SC-D24	277 V, 1600 W, 24" Long	EL-HO-D24	277 V, 1360 W, 24" Long
EL-SC-G24	480 V, 1600 W, 24" Long	EL-HO-G24	480 V, 1360 W, 24" Long
EL-SC-B33	208 V, 2500 W, 33" Long	EL-HO-B33	208 V, 2125 W, 33" Long
EL-SC-C33	240 V, 2500 W, 33" Long	EL-HO-C33	240 V, 2125 W, 33" Long
EL-SC-D33	277 V, 2500 W, 33" Long	EL-HO-D33	277 V, 2125 W, 33" Long
EL-SC-G33	480 V, 2500 W, 33" Long	EL-HO-G33	480 V, 2125 W, 33" Long
EL-SC-D46	277 V, 3200 W, 46" Long	EL-HO-D46	277 V, 3200 W, 46" Long
EL-SC-G46	480 V, 3650 W, 46" Long	EL-HO-G46	480 V, 3200 W, 46" Long
EL-SC-H46	575 V, 3800 W, 46" Long	EL-HO-H46	575 V, 3200 W, 46" Long
Short Wave - Ruby		Medium Wave	
EL-SR-A24	120 V, 1500 W, 24" Long	EL-MW-A24	120 V, 750 W, 24" Long
EL-SR-B24	208 V, 1600 W, 24" Long	EL-MW-B24	208 V, 750 W, 24" Long
EL-SR-C24	240 V, 1600 W, 24" Long	EL-MW-C24	240 V, 750 W, 24" Long
EL-SR-D24	277 V, 1600 W, 24" Long	EL-MW-D24	277 V, 750 W, 24" Long
EL-SR-G24	480 V, 1600 W, 24" Long	EL-MW-A33	120 V, 1250 W, 33" Long
EL-SR-B33	208 V, 2500 W, 33" Long	EL-MW-B33	208 V, 1250 W, 33" Long
EL-SR-C33	240 V, 2500 W, 33" Long	EL-MW-C33	240 V, 1250 W, 33" Long
EL-SR-D33	277 V, 2500 W, 33" Long	EL-MW-D33	277 V, 1250 W, 33" Long
EL-SR-G33	480 V, 2500 W, 33" Long	EL-MW-B46	208 V, 2000 W, 46" Long
EL-SR-D46	277 V, 3200 W, 46" Long	EL-MW-C46	240 V, 2000 W, 46" Long
EL-SR-G46	480 V, 3650 W, 46" Long	EL-MW-D46	277 V, 2000 W, 46" Long
EL-SR-H46	575 V, 3800 W, 46" Long	EL-MW-G46	480 V, 2000 W, 46" Long
		EL-MW-H46	575 V, 3000 W, 46" Long

4.0 Limited Warranty

One-Year Limited Warranty. Detroit Radiant Products Company (hereinafter referred to as the Company) warrants to the original purchaser or original user that all Detroit Radiant Electric Infrared Heaters sold by it and all parts thereof are free from defects in material or workmanship under normal use and service. The Company's sole obligation under this warranty shall be limited to furnishing replacement parts, F.O.B. Warren, Michigan, for 12 months from the date of initial installation of the heater, but not to exceed 18 months from the date of shipment by the Company of the heaters, for any parts which the Company's examination shall disclose to its satisfaction to be defective. Defective parts are to be returned to the Company, transportation charges prepaid.

General Conditions. The warranties set out in this certificate are the exclusive remedy of the original owner or user in lieu of all other warranties written, oral or implied (including any warranty of merchantability or fitness for the purpose) and all other obligations or liabilities on the part of the Company, and the Company neither assumes nor authorizes any person to assume for it any other obligation or liabilities on the part of the Company, and the Company neither assumes nor authorizes any person to assume for it any other obligation or liability in connection with the sale, installation or use of the heater or any parts thereof.

The Company will not be responsible for labor charges for the analysis of a defective condition in the heater or for the installation of replacement parts. The warranties provided herein will not apply if the input of the heater exceeds the rated input at time of manufacturing or if the heater in the judgment of the Company has been subjected to misuse, excessive dust, improper conversion, negligence, accident, corrosive atmospheres, excessive thermal shock, excessive vibration, physical damage to the heater, alterations by unauthorized service personnel, operation contrary to the Company's instructions or if the serial number has been altered, defaced, or removed. The Company shall not be liable for any default or delay in the performance of these warranties caused by contingency beyond its control, including war, government restriction or restraints, strikes, fire, flood, short or reduced supply of raw materials, or parts.

The warranties herein shall be null and void if the heater is not installed by a competent heating contractor and/or if the heater is not installed according to Company instructions, normal industry practices and/or if the heater is not maintained and repaired according to Company's instructions. Normal product degradation and wear (rust, oxidation, etc.) does not constitute a material defect and applicable warranty claim.

Written permission is required for the return of any parts or equipment and any such return must be made on the basis of transportation charges prepaid. Shipment may be refused unless prior written permission is obtained and goods returned prepaid.



© 2023 Detroit Radiant Products Co.
21400 Hoover Road, Warren, MI 48089
Phone: (586) 756-0950 • Fax: (586) 756-2626
www.detroitradiant.com • sales@drp-co.com

